

# AutoDome<sup>®</sup> and EnviroDome<sup>®</sup> Indoor Pendant In-ceiling Model Installation Manual Version 5.3



Security Systems

EN

**AutoDome**  
with AutoTrack



Security you can rely on

# BOSCH

## Important Safeguards

1. **Read, Follow, and Retain Instructions** - All safety and operating instructions should be read and followed before operating the unit. Retain instructions for future reference.
2. **Heed Warnings** - Adhere to all warnings on the unit and in the operating instructions.
3. **Attachments** - Attachments not recommended by the product manufacturer should not be used, as they may cause hazards.
4. **Installation Cautions** - Do not place this unit on an unstable stand, tripod, bracket, or mount. The unit may fall, causing serious injury to a person and serious damage to the unit. Use only manufacturer-recommended accessories, or those sold with the product. Mount the unit per the manufacturer's instructions. Appliance and cart combination should be moved with care. Quick stops, excessive force, or uneven surfaces may cause the appliance and cart combination to overturn.
5. **Cleaning** - Unplug the unit from the outlet before cleaning. Follow any instructions provided with the unit. Generally, using a damp cloth for cleaning is sufficient. Do not use liquid cleaners or aerosol cleaners.
6. **Servicing** - Do not attempt to service this unit yourself. Opening or removing covers may expose you to dangerous voltage or other hazards. Refer all servicing to qualified service personnel.
7. **Damage Requiring Service** - Unplug the unit from the main AC power source and refer servicing to qualified service personnel under the following conditions:
  - When the power supply cord or plug is damaged.
  - If liquid has been spilled or an object has fallen into the unit.
  - If the unit has been exposed to water and/or inclement weather (rain, snow, etc.).
  - If the unit does not operate normally, when following the operating instructions. Adjust only those controls specified in the operating instructions. Improper adjustment of other controls may result in damage, and require extensive work by a qualified technician to restore the unit to normal operation.
  - If the unit has been dropped or the cabinet damaged.
  - If the unit exhibits a distinct change in performance, this indicates that service is needed.
8. **Replacement Parts** - When replacement parts are required, the service technician should use replacement parts specified by the manufacturer, or that have the same characteristics as the original part. Unauthorized substitutions may result in fire, electrical shock, or other hazards.
9. **Safety Check** - Upon completion of servicing or repairs to the unit, ask the service technician to perform safety checks to ensure proper operating condition.
10. **Power Sources** - Operate the unit only from the type of power source indicated on the label. If unsure of the type of power supply to use, contact your dealer or local power company.
  - For units intended to operate from battery power, refer to the operating instructions.
  - For units intended to operate **with External Power Supplies**, use only the recommended approved power supplies.
  - For units intended to operate with a limited power source, this power source must comply with EN60950. Substitutions may damage the unit or cause fire or shock.
  - For units intended to operate at 24 VAC, normal input voltage is **24 VAC**. Voltage applied to the unit's power input should not exceed 30 VAC. User-supplied wiring, from the 24 VAC supply to unit, must be in compliance with electrical codes (Class 2 power levels). Do not ground the 24 VAC supply at the terminals or at the unit's power supply terminals.
11. **Coax Grounding** - If an outside cable system is connected to the unit, ensure that the cable system is grounded. U.S.A. models only--Section 810 of the National Electrical Code, ANSI/NFPA No.70, provides information regarding proper grounding of the mount and supporting structure, grounding of the coax to a discharge unit, size of grounding conductors, location of discharge unit, connection to grounding electrodes, and requirements for the grounding electrode.
12. **Grounding or Polarization** - This unit may be equipped with a polarized alternating current line plug (a plug with one blade wider than the other). This safety feature allows the plug to fit into the power outlet in only one way. If unable to insert the plug fully into the outlet, try reversing the plug. If the plug still fails to fit, contact an electrician to arrange replacement of the obsolete outlet. Do not defeat the safety purpose of the polarized plug. Alternately, this unit may be equipped with a 3-wire grounding plug (a plug with a third pin, for grounding). This safety feature allows the plug to fit into a grounding power outlet only. If unable to insert the plug into the outlet, contact an electrician to arrange replacement of the obsolete outlet. Do not defeat the safety purpose of the grounding plug.
13. **Lightning** - For added protection during a lightning storm, or when this unit is left unattended and unused for long periods of time, unplug the unit from the wall outlet and disconnect the cable system. This will prevent damage to the unit due to lightning and power line surges.

**For Indoor Product**

1. **Water and Moisture** - Do not use this unit near water - for example, in a wet basement, in an unprotected outdoor installation, or in any area classified as a wet location.
2. **Object and Liquid Entry** - Never push objects of any kind into this unit through openings, as they may touch dangerous voltage points or short out parts that could result in a fire or electrical shock. Never spill liquid of any kind on the unit.
3. **Power Cord and Power Cord Protection** - For units intended to operate with 230VAC, 50Hz, the input and output power cord must comply with the latest versions of IEC Publication 227 or IEC Publication 245.  
Power supply cords should be routed so they are not likely to be walked on or pinched. Pay particular attention to location of cords and plugs, convenience receptacles, and the point of exit from the appliance.
4. **Overloading** - Do not overload outlets and extension cords; this can result in a risk of fire or electrical shock.

**For Outdoor Product**

**Power Lines** - An outdoor system should not be located in the vicinity of overhead power lines, electric lights, or power circuits, or where it may contact such power lines or circuits. When installing an outdoor system, extreme care should be taken to keep from touching power lines or circuits, as this contact might be fatal. U.S.A. models only - refer to the National Electrical Code Article 820 regarding installation of CATV systems.

**For Rack-Mount Product**

1. **Ventilation** - This unit should not be placed in a built-in installation or rack, unless proper ventilation is provided, or the manufacturer's instructions have been adhered to. The equipment must not exceed its maximum operating temperature requirements.
2. **Mechanical Loading** - Mounting of the equipment in a rack shall be such that a hazardous condition is not achieved due to uneven mechanical loading.

**Safety Precautions****CAUTION**

RISK OF ELECTRIC SHOCK. DO NOT OPEN!



**CAUTION: TO REDUCE THE RISK OF ELECTRIC SHOCK, DO NOT REMOVE COVER (OR BACK). NO USER SERVICEABLE PARTS INSIDE. REFER SERVICING TO QUALIFIED SERVICE PERSONNEL.**



This symbol indicates the presence of uninsulated "dangerous voltage" within the product's enclosure that can cause an electric shock.



This symbol indicates the presence of important operating and maintenance (servicing) instructions in the literature accompanying the appliance.



Installation should be performed by qualified service personnel only in accordance with the National Electrical Code or applicable local codes.



**Power Disconnect.** Units with or without ON-OFF switches have power supplied to the unit whenever the power cord is inserted into the power source; however, the unit is operational only when the ON-OFF switch is in the ON position. The power cord is the main power disconnect for all units.

**FCC & ICES INFORMATION****(U.S.A. and Canadian Models Only)**

This device complies with part 15 of the FCC Rules.

Operation is subject to the following two conditions:

- (1) This device may not cause harmful interference, and
- (2) This device must accept any interference received, including interference that may cause undesired operation.

**NOTE:** This equipment has been tested and found to comply with the limits for a Class A digital device, pursuant to Part 15 of the FCC Rules and ICES-003 of Industry Canada. These limits are designed to provide reasonable protection against harmful interference when the equipment is operated in a commercial environment. This equipment generates, uses and radiates radio frequency energy, and if not installed and used in accordance with the instruction manual, may cause harmful interference to radio communications. Operation of this equipment in a residential area is likely to cause harmful interference, in which case the user will be required to correct the interference at his expense.

Intentional or unintentional changes or modifications, not expressly approved by the party responsible for compliance, shall not be made. Any such changes or modifications could void the user's authority to operate the equipment. If necessary, the user should consult the dealer or an experienced radio/television technician for corrective action.





The user may find the following booklet, prepared by the Federal Communications Commission, helpful:

[How to Identify and Resolve Radio-TV Interference Problems](#). This booklet is available from the U.S.







Government Printing Office, Washington, DC 20402, Stock No. 004-000-00345-4.

**WARNING:** This is a Class A product. In a domestic environment, this product may cause radio interference, in which case, the user may be required to take adequate measures.





**Sécurité**

	<b>ATTENTION</b> RISQUE D'ÉLECTROCUTION. NE PAS OUVRIR!	
<b>ATTENTION : POUR ÉVITER TOUT RISQUE D'ÉLECTROCUTION, N'ESSAYEZ PAS DE RETIRER LE CAPOT (OU LE PANNEAU ARRIÈRE). CET APPAREIL NE CONTIENT AUCUN COMPOSANT SUSCEPTIBLE D'ÊTRE RÉPARÉ PAR L'UTILISATEUR. CONFIEZ LA RÉPARATION DE L'APPAREIL À DU PERSONNEL QUALIFIÉ.</b>		
	Ce symbole signale que le produit renferme une « tension potentiellement dangereuse » non isolée susceptible de provoquer une électrocution.	
	Ce symbole invite l'utilisateur à consulter les instructions d'utilisation et d'entretien (dépannage) reprises dans la documentation qui accompagne l'appareil.	
	Attention : l'installation doit exclusivement être réalisée par du personnel qualifié, conformément au code national d'électricité américain (NEC) ou au code d'électricité local en vigueur.	
	Coupeure de l'alimentation. Qu'ils soient pourvus ou non d'un commutateur ON/OFF, tous les appareils reçoivent de l'énergie une fois le cordon branché sur la source d'alimentation. Toutefois, l'appareil ne fonctionne réellement que lorsque le commutateur est réglé sur ON. Le débranchement du cordon d'alimentation permet de couper l'alimentation des appareils.	

**Sicherheitshinweise**

	<b>VORSICHT</b> ELEKTRISCHE SPANNUNG. NICHT ÖFFNEN!	
<b>VORSICHT: UM EINEN ELEKTRISCHEN SCHLAG ZU VERMEIDEN, IST DIE ABDECKUNG (ODER RÜCKSEITE) NICHT ZU ENTFERNEN. ES BEFINDEN SICH KEINE TEILE IN DIESEM BEREICH, DIE VOM BENUTZER GEWARTET WERDEN KÖNNEN. LASSEN SIE WARTUNGSARBEITEN NUR VON QUALIFIZIERTEM WARTUNGSPERSONAL AUSFÜHREN.</b>		
	Das Symbol macht auf nicht isolierte „gefährliche Spannung“ im Gehäuse aufmerksam. Dies kann zu einem elektrischen Schlag führen.	
	Der Benutzer sollte sich ausführlich über Anweisungen für die Bedienung und Instandhaltung (Wartung) in den begleitenden Unterlagen informieren.	
	Achtung! Die Installation sollte nur von qualifiziertem Kundendienstpersonal gemäß jeweils zutreffender Elektrovorschriften ausgeführt werden.	
	Unterbrechung des Netzanschlusses. Geräte mit oder ohne Netzschalter haben Spannung am Gerät anliegen, sobald der Netzstecker in die Steckdose gesteckt wird. Das Gerät ist jedoch nur betriebsbereit, wenn der Netzschalter (EIN/AUS) auf EIN steht. Wenn das Netzkabel aus der Steckdose gezogen wird, ist die Spannungszuführung zum Gerät vollkommen unterbrochen.	



## Precauciones de Seguridad

	<b>ATTENZIONE</b> PERICOLO DI SCOSSA ELETTRICA. NON APRIRE.	
<p><b>PRECAUCIÓN: PARA DISMINUIR EL RIESGO DE DESCARGA ELÉCTRICA, NO RETIRE LA CUBIERTA (NI LA PARTE POSTERIOR). NO EXISTEN PIEZAS DE RECAMBIO EN EL INTERIOR DEL EQUIPO. EL PERSONAL DE SERVICIO CUALIFICADO SE ENCARGA DE REALIZAR LAS REPARACIONES.</b></p>		
	Este símbolo indica que existen puntos de tensión peligrosos sin aislamiento dentro de la cubierta de la unidad. Estos puntos pueden constituir un riesgo de descarga eléctrica.	
	El usuario debe consultar las instrucciones de funcionamiento y mantenimiento (reparación) en la documentación que se suministra con el aparato.	
	Atención: la instalación la debe realizar únicamente personal cualificado de conformidad con el National Electric Code o las normas aplicables en su país.	
	Desconexión de la alimentación. Las unidades con o sin interruptores de encendido/apagado reciben alimentación eléctrica siempre que el cable de alimentación esté conectado a la fuente de alimentación. Sin embargo, la unidad sólo funciona cuando el interruptor está en la posición de encendido. El cable de alimentación es la principal fuente de desconexión de todas las unidades.	







## Sicurezza

	<b>ATTENZIONE</b> PERICOLO DI SCOSSA ELETTRICA. NON APRIRE.	
<p><b>ATTENZIONE: PER RIDURRE IL RISCHIO DI SCOSSE ELETTRICHE NON RIMUOVERE LA COPERTURA (O IL PANNELLO POSTERIORE). L'UNITÀ NON CONTIENE COMPONENTI INTERNI RIPARABILI DALL'UTENTE. PER QUALSIASI INTERVENTO, RIVOLGERSI A PERSONALE TECNICO QUALIFICATO.</b></p>		
	Questo simbolo indica la presenza di "tensione pericolosa" non isolata all'interno del contenitore del prodotto. Ciò comporta un potenziale rischio di scosse elettriche.	
	Si consiglia di consultare le istruzioni operative e di manutenzione (interventi tecnici) contenute nella documentazione fornita con il dispositivo.	
	Attenzione: l'installazione deve essere effettuata esclusivamente da personale tecnico qualificato in conformità con il National Electrical Code o con le normative locali vigenti.	
	Scollegamento dell'alimentazione. Le unità dotate o sprovviste di interruttori ON-OFF vengono alimentate quando si inserisce il cavo nella presa dell'alimentazione. L'unità è tuttavia in funzione solo quando l'interruttore ON-OFF si trova nella posizione ON. Il cavo di alimentazione costituisce il dispositivo di scollegamento dell'alimentazione principale per tutte le unità.	

## Veiligheidsmaatregelen

	<b>VOORZICHTIG</b> GEVAARVOOR ELEKTRISCHE SCHOK. NIET OPENEN!	
<p><b>VOORZICHTIG: OPEN DE BEHUIZING OF DE ACHTERKANT VAN HET APPARAAT NIET. ZO VERMINDERT U HET RISICO OP ELEKTRISCHE SCHOKKEN. IN HET APPARAAT BEVINDEN ZICH GEEN ONDERDELEN DIE U ZELF KUNT REPAREREN. LAAT SERVICE EN ONDERHOUD UITVOEREN DOOR GEKWALIFICEERD PERSONEEL.</b></p>		
	Dit symbool geeft aan dat er binnen in het apparaat ongeïsoleerde, gevaarlijke spanning aanwezig is die mogelijk elektrische schokken kan veroorzaken.	
	De gebruiker dient de bedienings- en onderhoudsvoorschriften te raadplegen in de documentatie die werd meegeleverd met het apparaat.	
	Attentie: het apparaat mag alleen door gekwalificeerd personeel worden geïnstalleerd. De installatie dient in overeenstemming met de nationale elektrische richtlijnen of de van toepassing zijnde lokale richtlijnen te worden uitgevoerd.	
	Spanning uitschakelen. Apparatuur met of zonder aan-uitschakelaar staat onder spanning zolang de stekker is aangesloten op de wandcontactdoos. De apparatuur is uitsluitend in werking als de aan-uitschakelaar aan staat. Het netsnoer is de "hoofdschakelaar" voor alle apparatuur.	

## Medidas de Segurança

	<b>CUIDADO</b> RISCO DE CHOQUE ELÉCTRICO. NÃO ABRIR!	
<p><b>CUIDADO: PARA REDUZIR O RISCO DE CHOQUE ELÉCTRICO, NÃO RETIRE A TAMPA (OU A PARTE POSTERIOR). NO INTERIOR, NÃO EXISTEM PEÇAS QUE POSSAM SER REPARADAS PELO UTILIZADOR. REMETA A ASSISTÊNCIA PARA OS TÉCNICOS QUALIFICADOS.</b></p>		
	Este símbolo indica a presença de "tensão perigosa" não isolada dentro da estrutura do produto, o que pode constituir risco de choque eléctrico.	
	O utilizador deve consultar as instruções de funcionamento e manutenção (assistência) nos documentos que acompanham o aparelho.	
	Atenção: a instalação deve ser executada apenas por técnicos qualificados da assistência, de acordo com o código eléctrico nacional ou os códigos locais aplicáveis.	
	Corte de corrente. As unidades com ou sem interruptores ON-OFF (ligar/desligar) recebem corrente sempre que o fio de alimentação está introduzido na fonte de alimentação; contudo, a unidade apenas está operacional quando o interruptor ON-OFF está na posição ON. O fio de alimentação destina-se a desligar a corrente em todas as unidades.	

## Zasady Bezpieczeństwa

**UWAGA****NIEBEZPIECZEŃSTWO PORAŻENIA PRĄDEM ELEKTRYCZNYM. NIE OTWIERAĆ!**

PRZESTROGA: ABY ZMNIJSZYĆ RYZYKO PORAŻENIA ELEKTRYCZNEGO, NIE NALEŻY ZDEJMOWAĆ POKRYWY GÓRNEJ (ani tylnej). WEWNĘTRZ URZĄDZENIA NIE MA ŻADNYCH ELEMENTÓW, KTÓRE MOGĄ BYĆ NAPRAWIANE SAMODZIELNIE PRZEZ UŻYTKOWNIKA. SERWIS NALEŻY ZLECAĆ WYKWALIFIKOWANYM PRACOWNIKOM OBSŁUGI.



Ten symbol wskazuje na obecność niez izolowanego „niebezpiecznego napięcia” we wnętrzu urządzenia. Napięcie to grozi porażeniem



Użytkownik powinien zapoznać się z instrukcjami obsługi i konserwacji (serwisu), zamieszczonymi w dokumentacji



Uwaga: Instalacja może być wykonywana wyłącznie przez wykwalifikowanych pracowników obsługi, zgodnie z zasadami kodeksu National Electrical Code lub innych obowiązujących norm.



Odłączenie zasilania niezależnie od wyposażenia w wyłącznik zasilania, prąd do urządzenia jest doprowadzany zawsze, gdy przewód zasilania jest podłączony do źródła zasilania; jednak urządzenie działa tylko wtedy, gdy wyłącznik zasilania jest

## Table of Contents

<b>SECTION 1</b>	
ENVIRODOME AND INDOOR PENDANT INSTALLATION INSTRUCTIONS .....	7
<b>SECTION 2</b>	
IN-CEILING AUTODOME INSTALLATION INSTRUCTIONS .....	11
<b>SECTION 3</b>	
FASTADDRESS .....	13
<b>SECTION 4</b>	
AUTODOME SECURITY .....	14
<b>SECTION 5</b>	
SECTOR BLANKING AND PRIVACY MASKS .....	15
<b>SECTION 6</b>	
CHANGING THE BAUD RATE FOR RS-232 OR RS-485 OPERATION .....	16
<b>SECTION 7</b>	
ALARMS .....	17
<b>SECTION 8</b>	
AUTOTRACK .....	19
<b>SECTION 9</b>	
PELCO PROTOCOL MODE .....	20
<b>SECTION 10</b>	
MAINTENANCE/COMPONENT REPLACEMENT .....	23
<b>SECTION 11</b>	
TROUBLESHOOTING GUIDE .....	24
<b>SECTION 12</b>	
AUTODOME LOCKED COMMANDS .....	26
<b>SECTION 13</b>	
ADVANCED MENU .....	27
<b>APPENDIX A</b>	
POWER WIRING GUIDE .....	34
<b>APPENDIX B</b>	
OPTIONAL GASKET INSTALLATION .....	35
<b>AUTODOME USER MANUAL (Insert)</b> .....	36
AUTODOME USER COMMANDS (Unlocked Commands) .....	39

**NOTE:** Before beginning installation, please remove the USER MANUAL in the back of this booklet.

## SECTION 1

### EnviroDome and Indoor Pendant Installation Instructions

#### Camera Addressing

- 1.1** To use FastAddress, skip to STEP 1F. Otherwise, to manually set the switch address, position the dome on the star shaped foam, with the bubble side down.



Photo 1A Position dome

- 1.2** Remove the 4 top screws as shown in PHOTO 1B, and lift the top plate carefully off the dome. The cable length is approximately 5 cm (2 in), so remove carefully from the PCB.

Remove the top plate cable (if necessary) from the dome to access the address switch. Set the address switch (as in STEP 1C) and make a note of it.



Photo 1B Remove screws

- 1.3** If using RS-232/RS-485 Communications:

The unit is shipped with the Baud Rate set to 9600. The baud rate may be changed via the COMMUNICATIONS SETUP menu (see SECTION 6).

The following dip switch settings pertain to AutoDome Versions 5.00 and newer.

Switch #	Function	Position	Selection
1	RESERVED		
2	Serial Mode Selection	ON OFF	RS-485 RS-232*
3	RESERVED		
4	Low Pressure Detection	ON OFF	Pressurized Dome Non-Pressurized Dome*

\*Default position for all switch settings is OFF.

Figure 1A S105 Dip Switch Settings

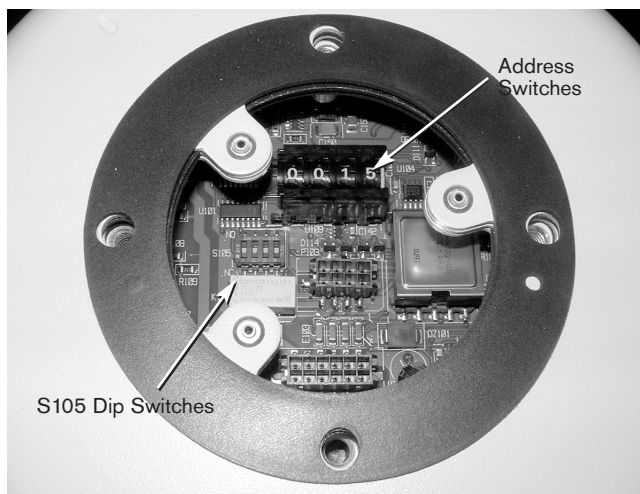

Photo 1C Set the address switch

**1.4** Reconnect the top plate cable, then replace the top plate and gasket (see PHOTO 1D). Align the ribs on the bottom of the top plate with the matching openings in the housing, then firmly tighten the four (4) screws.



Photo 1D Replace top plate

**1.5** To avoid confusion during installation, write the camera address on masking tape and stick it to the dome, as shown in PHOTO 1E.

The dome is now ready to be installed, using an appropriate AutoDome mount.

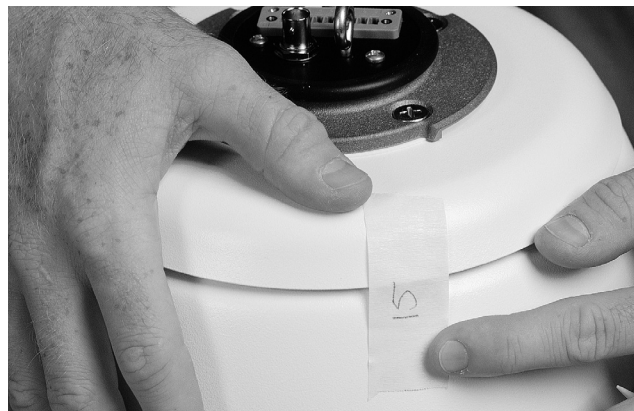

Photo 1E Write camera address

**!** Installation should be performed by qualified service personnel only, in accordance with the National Electrical Code or applicable local codes. Refer to the appropriate installation section.

The AutoDome can be mounted to a wall, mast (pole), roof, pipe, or a corner mount once the appropriate mount has been installed. Each mount includes its own mounting instructions.

**!** Mounts must be properly and securely mounted to a supporting structure capable of sustaining the unit weight.\*\*Use care when selecting mounting hardware (not supplied) for installation. The mounting surface and unit's weight should be carefully considered.

The following instructions reference a 120/230 VAC pendant wall plate installation mounted to an existing structure. The instructions assume the safety cable, power, video, and control cables have already been properly installed.

\*\*Refer to mounting instructions.

- 1.6 Attach the installation-assist cable\* to the eyehook on the top of the dome, and close the safety cable (see PHOTO 1F).

\* A cable (user-provided) is recommended for safety purposes when pipe mounting. See Mounting Guide for instructions.

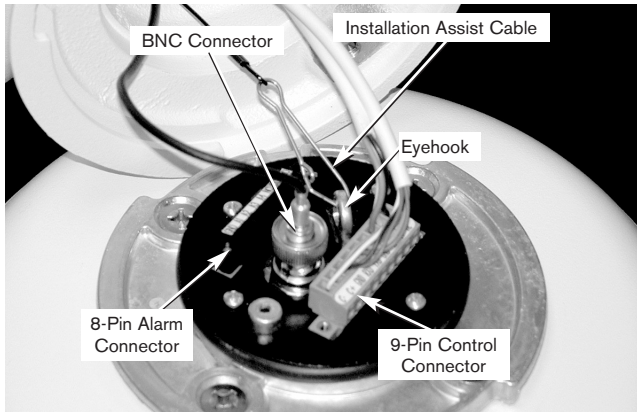

Photo 1F Connections

1.7 MAKE THE FOLLOWING CONNECTIONS:

\*\*If the AutoDome is programmed for RS-485 operation, RXD functions as DATA (+), and TXD functions as DATA (-).

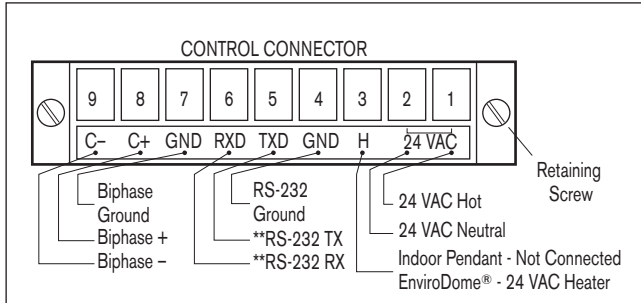

Figure 1B Control connector

- a. If the Alarm Inputs or the Relay Output are being used, connect the appropriate wires to the 8-pin Alarm connector (see FIGURE 1C).

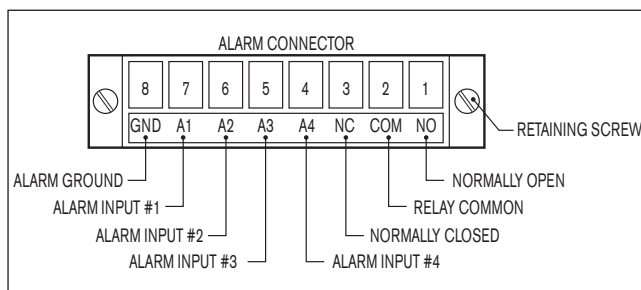

Figure 1C Alarm connector

- b. Connect Video (BNC) cable and the CONTROL connector. Tighten screws on control connector.
- c. When using Biphase, and the dome is in a star configuration (or is the last dome on a daisy chain), it requires a 110 Ω terminating resistor (included) across pin 8 (C+) and pin 9 (C-).

**!** Daisy chain configuration is not possible if fiber optic accessory is used.

1.8 AUTODOME 24 VAC INSTRUCTIONS  
ENVX2450X, ENVX2460X, G3AX5X, and G3AX6X Kits

Check for the following:

- a. An ENV-PSU (or equivalent) power supply must be used.
- b. Be sure to use an adequate gauge of 24 VAC wiring for the distance run. See APPENDIX A - Power Wiring Guide for proper wiring instructions and recommended wire run lengths.
- c. Wire the 9-pin CONTROL connector located on the top of the unit, as in STEP 1G.
- d. If the Alarm Inputs or Relay Output are being used, connect the appropriate wires to the 8-pin Alarm connector.

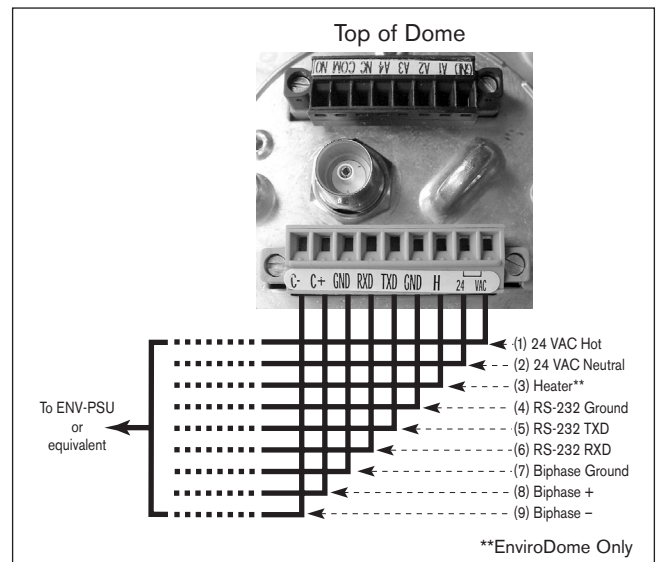

Figure 1D

**!** If not using an ENV-PSU, place a jumper between Pin (1) 24 VAC Hot and Pin (3) Heater (see APPENDIX A for details).

- 1.9 Align the notch on the AutoDome with the notch on the FRONT of the Pendant Arm.

Lift the AutoDome into the Pendant Arm and twist until the notch on the AutoDome is aligned with the notch on the SIDE of the pendant arm.

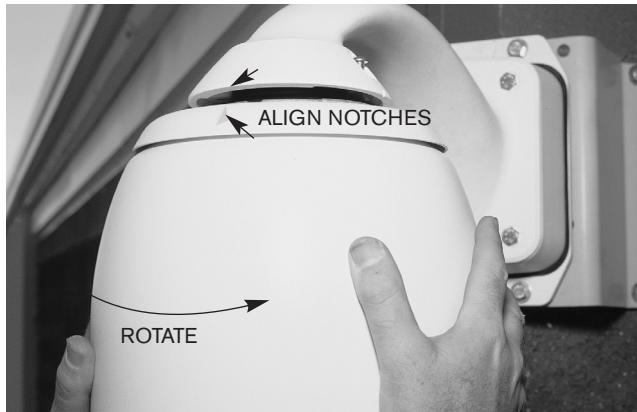

Photo 1G Align notches

- 1.10** Tighten the two screws on the top of the pendant arm until snug.



Photo 1H Tighten screws



Some models require a slotted screw instead of an Allen screw.

Apply power to the AutoDome.

- 1.11** If using the FastAddress feature, see SECTION 3 for additional information.

**Congratulations!** You've installed the AutoDome.



Photo 1I Installed AutoDome

**SECTION 2**

**In-ceiling AutoDome  
Installation Instructions**

**2.1** Before installing this unit, install and wire the In-ceiling Backbox (LTC 7490), following the instructions provided with that unit.

Carefully remove the AutoDome from the box. Save all packing material, to be used for setup and transport of the camera and dome.

If an item appears to have been damaged in shipment, notify the shipper. If any items are missing, notify your Bosch Sales or Customer Service Representative at the location nearest you. See our Web site at [www.boschsecurity.com](http://www.boschsecurity.com).

If using RS-232/RS-485 Communications:

The unit is shipped with the RS-232/RS-485 Baud Rate set to 9600. This rate can be changed via the COMMUNICATIONS SETUP menu (see SECTION 6).

The following settings pertain to AutoDome versions 5.00 and newer:

Switch #	Function	Position	Selection
1	RESERVED		
2	Serial Mode Selection	ON OFF	RS-485 RS-232*
3	RESERVED		
4	Low Pressure Detection	ON OFF	Pressurized Dome Non-Pressurized Dome*

\*Default position for all switch settings is OFF.

Figure 2A S105 Dip Switch Settings



Photo 2A In-ceiling AutoDome

**2.2** To use FastAddress, skip to STEP 2C. Otherwise, set the address switch as shown. Setting address selector to 0000 causes the AutoDome to respond to ALL messages regardless of address (NOT RECOMMENDED); otherwise, the unit only responds to commands issued for that address.

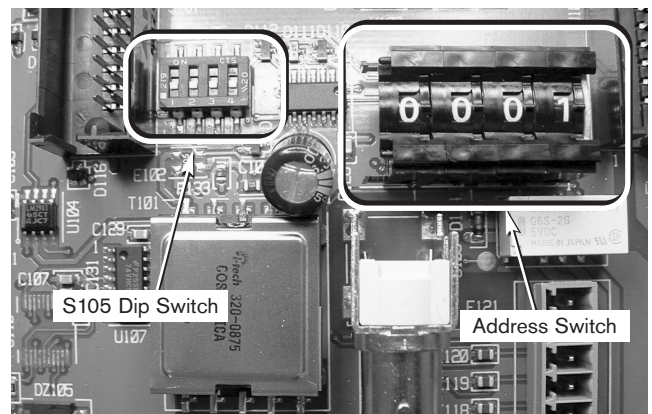

Photo 2B S105 Dip switch and Address selector

- 2.3** Attach the dome window to the camera module, aligning the blue LOCK labels.

Snap the dome cover into position by pressing gently on the dome 90° from the blue labels.

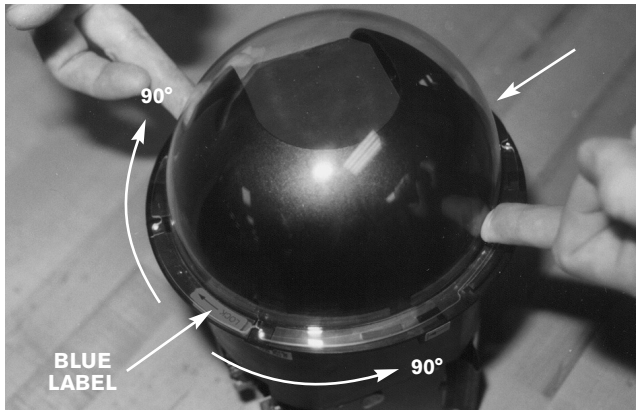

Photo 2C Attach dome window

- 2.4** While holding the top of the camera, rotate the lower portion and align the camera dome yellow markers.

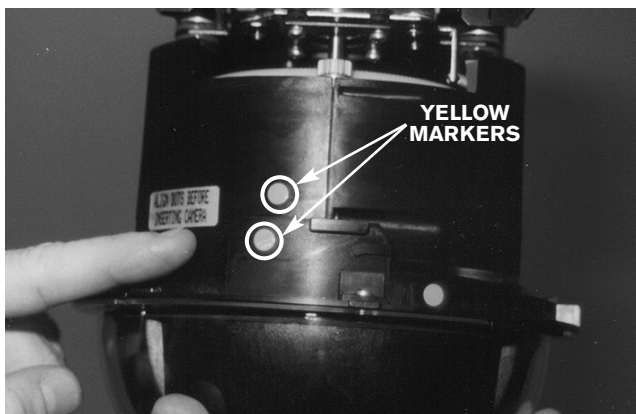

Photo 2D Align yellow markers

- 2.5** With the red dot on the camera module facing the red dot on the backbox, slide the camera module into the backbox module using the guides. Note that the camera is shown turned 180 degrees to illustrate red markers.

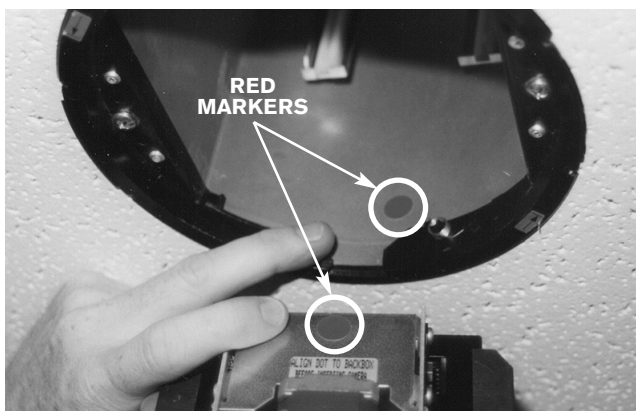

Photo 2E Align red markers

- 2.6** While grasping the unit by the dome window, insert the camera module completely into the backbox.

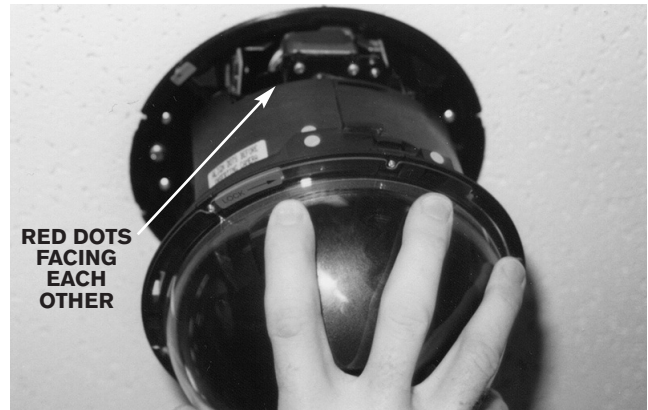

Photo 2F Insert camera module

- 2.7** While pressing up, twist the dome window/locking ring clockwise approximately 1/4 turn. The camera will initialize ten seconds after it is properly installed.



Photo 2G Lock dome into place

- 2.8** An optional tamper clip is provided to prevent the dome from being removed. To install, locate the blue label, orient the tamper clip with the two tabs pointing up, and press the tamper clip into the locking ring just to the right of either blue label. A straight blade screwdriver will help push the clip in place.

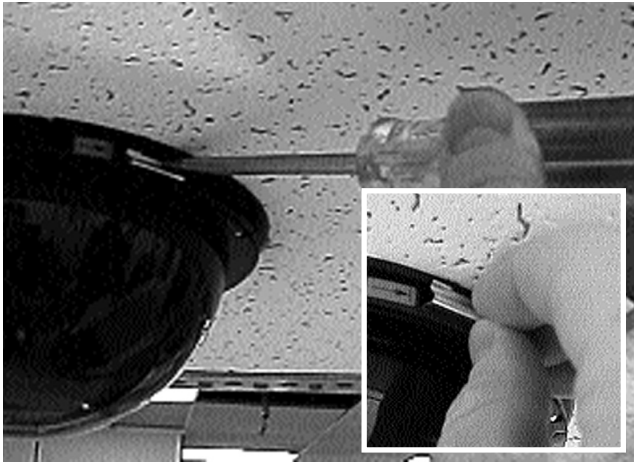

Photo 2H Optional tamper clip

- 2.9** To install the trim ring, align the yellow dots on the inside of the trim ring with the yellow dots on the locking ring. To ensure proper installation, push on the trim ring vertically until a click is felt. Installation is now complete.

If using the FastAddress feature, see SECTION 3 for additional information.

## 2.10 INSTALLATION



Installation should be performed by qualified service personnel only, in accordance with the National Electrical Code or applicable local codes.

The AutoDome system is suitable for use in environmental air spaces or in an air handling plenum of a nonfire-resistant ceiling.



Do not remove camera from pan/tilt. Remove the entire receiver/driver, pan/tilt, and camera assembly from the AutoDome system to prevent damage to the flexible cable and connector.

## SECTION 3

### FastAddress

The FastAddress feature allows the AutoDome's cameras to be addressed (or the address may be changed) via a keyboard and on-screen menus instead of using the switch address (thumbwheel). If FastAddress is not used, the camera's address defaults to the address indicated by the thumbwheel switches. Conversely, if FastAddress has been programmed, the thumbwheel switches are ignored.

There are two commands used to address the AutoDome via the FastAddress feature:

- ON-999-ENTER: All domes that have not already been configured using FastAddress will respond to this command. Additionally, if the address of a previously configured dome matches the camera number at the keyboard, that dome will respond to the command as well.
- ON-998-ENTER: All domes respond to this command, regardless of FastAddress status.

**NOTE:** In systems with multiple monitors, other domes may also enter the FastAddress mode. As commands (which are unique for each dome) are entered, the other domes automatically exit the FastAddress mode, and only the target dome remains active. Following are some instances when FastAddress would be used:

1. New or existing installation of an AutoDome(s):
  - a. Set the keyboard to display the camera, for example, CAMERA-3-ENTER (where 3 is the camera whose address you're identifying/changing).
  - b. Press ON-999-ENTER, and follow the instructions on the screen (see FIGURE 3A).

**REMINDER:** All domes that have not already been configured using FastAddress will respond to ON-999-ENTER.

- c. When a camera is being moved, the dome may already have an address, therefore it will not respond to ON-999-ENTER. In this case, you must use ON-998-ENTER to readdress the camera, then follow the on-screen instructions.
  - d. There is a visual confirmation that the address was set.
2. Clearing the address of a camera (causing the address of the camera to revert back to the address set by the thumbwheel):
  - a. Enter FastAddress mode using either method described above, then follow the on-screen instructions (see FIGURE 3B).
  - b. At the end of FastAddress mode, press OFF-1-ENTER to clear the address.

- c. There is a visual confirmation that the address was cleared.  
Use ON-997-ENTER to check/confirm camera addresses.  
For example, if referring to Camera 3, press  
CAMERA-3-ENTER, then ON-997-ENTER. This causes all  
cameras to briefly display their addresses.

FastAddress is stored to nonvolatile memory, thus will not change if power is removed or factory defaults are restored (SET-899-ENTER).

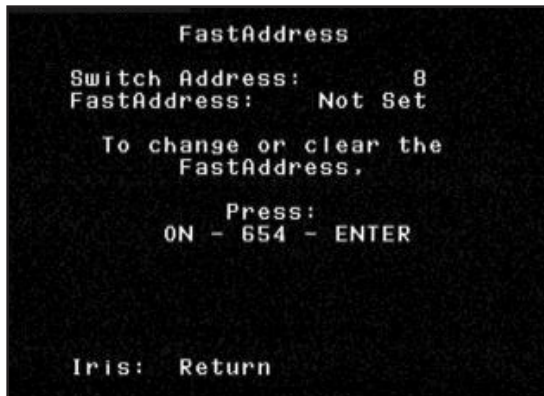

Figure 3A Enter new address



Figure 3B Clearing address

## SECTION 4

### AutoDome SECURITY

The AutoDome has password protection capability for Advanced Menu access and other locked commands.

To set a password, after entering OFF-90-ENTER, enter SET-802-ENTER and follow the on-screen instructions to set or change the password. Passwords are four (4) digits in length and are selected via the joystick.

The AutoDome's default password of 0000 <four zeros> allows OFF-90-ENTER to directly unlock the Advanced Menu commands. If the password of 9999 is used, the AutoDome is totally unlocked so that all AutoDome commands can be executed (no OFF-90-ENTER is required to use ADVANCED COMMANDS).

If any other 4-digit password is set, the AutoDome prompts for entry of a password when the unlock command, OFF-90-ENTER, is entered.

## SECTION 5

## SECTOR BLANKING AND PRIVACY MASKS

SECTOR BLANKING simply blanks all video in a specified sector. Sectors are defined as 1/16 of the total 360° field-of-view. Any combination of these sectors can be blanked via the BLANKING MENU, ON-86-ENTER.

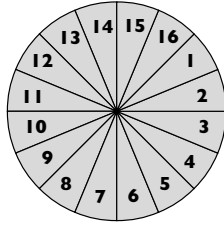

PRIVACY MASKS give the installer the opportunity to black out (mask) areas from visibility. Up to six (6) rectangular Privacy Masks can be defined. These masks change location and size as the camera pans, tilts and zooms.

When entering the PRIVACY MASKING screen (ON-87-ENTER), a list of masks is displayed for on-screen selection. An \* at the front of the line indicates that the mask is currently occupied, and if selected, the mask will be overwritten. The first available (unused) Privacy Mask is indicated by an arrow at the left margin, as shown below in FIGURE 5A.



Figure 5A Privacy Masking menu

Use the joystick to scroll through the list of masks until the desired mask is highlighted.

While in the PRIVACY MASKING menu, the following commands are available:

- FOCUS+ draws a new Privacy Mask (or edits an existing mask). A 1x1 block is drawn in the center of the screen (as shown in FIGURE 5B).
- FOCUS- deletes the selected mask (and removes the \*, signifying that the mask is now unused).
- IRIS+ moves the AutoDome so that the highlighted mask is centered on the screen.
- IRIS- exits the menu.

TO CREATE A MASK:

1. First, use the joystick to maneuver to the area to be masked, then zoom in so that this area is between 25% to 50% of the total screen.
2. Press ON-87-ENTER to enter the menu (as shown in FIGURE 5A). Use the joystick to scroll through the list of masks until the desired mask is highlighted. Press Focus+ to edit this mask.
3. If desired, use the joystick to adjust the area to be masked. Pan, Tilt, and Zoom are all available to reposition the camera to the view that is to be masked. Press FOCUS to continue (as shown in FIGURE 5B).

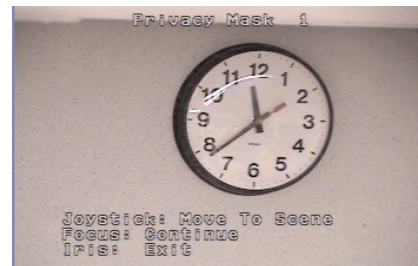

Figure 5B Reposition Camera

4. Use the joystick to move the masking block to the center of the area to be masked. Press either FOCUS button to anchor the mask (as shown in FIGURE 5C).



Figure 5C Move Block

5. Use the joystick to modify the mask's dimensions by moving to the right and down. Ensure that the mask is larger than the object/area to be masked (as shown in FIGURE 5D).



Figure 5D Modify Mask

- Press FOCUS again to continue. The AutoDome now adjusts its zoom position and allows fine-tuning of the mask coverage by using the joystick. FIGURE 5E shows a sample mask.



Figure 5E Adjusts Mask

- When finished fine-tuning the mask, press either IRIS button to exit the menu and save the current mask. Verify sufficient mask coverage by panning, tilting and zooming through the field-of-view.

## SECTION 6

### CHANGING THE COMMUNICATION SETUP FOR RS-232, RS-485 OR Bilinx™

If RS-232 or RS-485 is used to control the AutoDome, the baud rate may be changed via the following steps:

- View the video from the camera on a monitor. Using an appropriate controller/keyboard, unlock the AutoDome menus using OFF-90-ENTER. *COMMAND: UNLOCKED* should briefly appear at the top of the monitor.
- Enter the *Setup* menu using ON-46-ENTER. The main *Setup* menu should appear, as follows:



Figure 6A Camera Setup

- Use the joystick to move down to the *Communication Setup* menu and press FOCUS on the controller/keyboard.

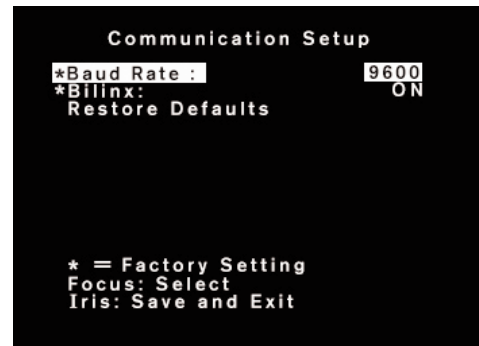

Figure 6B Communication Setup

- Press and release FOCUS until the desired baud rate appears. Then press IRIS to SAVE and EXIT.
- A countdown message will appear to confirm the baud rate change. If the baud rate of the controller is changed within 60 seconds, and the joystick is moved in any direction, the baud rate will be saved and made active. If the joystick is not moved at all, the AutoDome will discard the change and revert back to the previous baud rate.

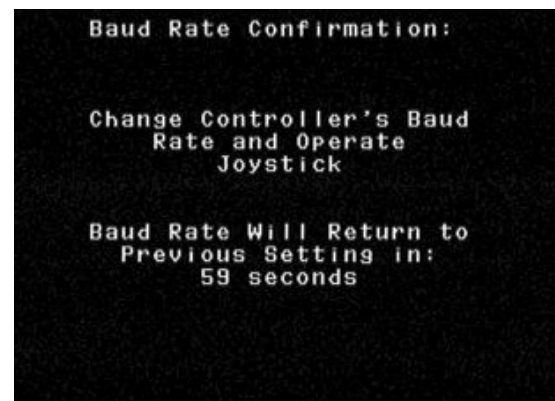

Figure 6C Baud Rate Confirmation

Versions 5.10 and higher of the AutoDome can also communicate directly through the coax using BILINX. The BILINX data communications may be disabled by changing the menu selection to OFF.

- Use the joystick to move down to the BILINX selection and press FOCUS on the controller/keyboard. The selection will change to OFF, and the BILINX data will be disabled.
- Press IRIS to SAVE and EXIT.

NOTE: For more information on how BILINX may be used to configure the camera, refer to the Configuration Tool software, P/N VP-CFGSFT.

## SECTION 7

## ALARMS

## 7.1 Inputs

There are four (4) Alarm Inputs that may be activated by a dry contact input closure. The alarm conditions must be present for greater than 200 ms to be recognized as a valid alarm. Each alarm input may be individually programmed for the type and desired Action to occur when an alarm is received (as shown in FIGURE 7A). The choices available are listed in FIGURE 12F in the back of this manual, and are explained in the Advanced Menu, SECTION 12.

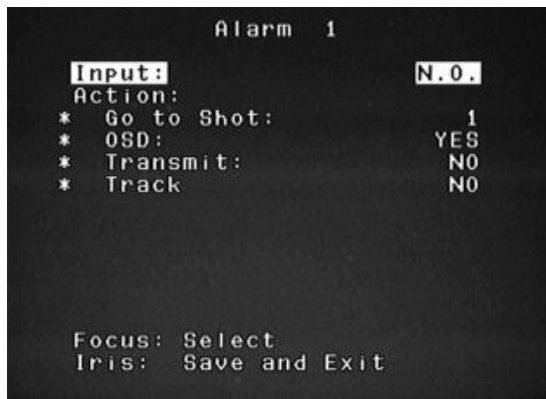

Figure 7A Input Setup Menu

The most important actions are GO TO SHOT and the OSD display. The camera may be programmed to go to any preprogrammed shot from 0 to 99. If 0 is entered as the SHOT number, the camera simply flashes the word *ALARM* on the monitor, but will not move from the current position (see PHOTO 7A).



Photo 7A Alarm active

The OSD may be turned OFF, and then the camera will move to the shot, but will not flash the word *ALARM*. To acknowledge an ALARM and turn off the flashing display, use the auxiliary command OFF-65-ENTER on a Bosch controller/keyboard. The *ALARM* message will be removed from the monitor, but if the contact closure is still activated, an "A" will appear in the top right-hand corner of the monitor, as shown in PHOTO 7B. When the contact input changes back to a non-alarm state, the "A" will be removed.



Photo 7B Alarm Acknowledged but still active

## 7.2 Low Pressure Alarm

The pressurized version of the AutoDome has an internal low-pressure sensor that is prewired to Alarm Input # 4. If the internal pressure is lost, the sensor activates the ALARM input, and instead of the word *ALARM* being displayed, the word *PRESSURE* will flash on the display, as shown in PHOTO 7C.



Photo 7C Low Pressure Alarm

When the pressure alarm is acknowledged using OFF-65-ENTER, the flashing display will stop, but the letter "P" will appear in the top right-hand corner of the monitor (PHOTO 7D). This AutoDome will continue to display this warning until the low-pressure problem has been corrected.



Photo 7D Low Pressure Alarm continued

### 7.3 Alarm Relay Output

The alarm relay output may be activated either manually, or triggered when an Alarm occurs. There are three possible choices for the time period that the relay output will remain activated. These choices are:

- 1 Follow input: This means it mimics the state of the alarm. As long as the alarm is active, the relay will be energized.
- 2 Latched: The relay will energize upon an alarm, and will remain energized until the user issues the command OFF-65-ENTER twice. The first time acknowledges the alarm and removes the OSD (if programmed to display), and the second time clears the alarm and resets the relay.
- 3 Specific length of time. This can be anywhere from one sec to ten min. An OFF-65-ENTER that's entered twice will again deactivate the relay, even if the timer has not yet expired.

These choices are also listed in the Advanced Menu, SECTION 12.

To manually activate the relay output from a Bosch controller/keyboard, use the sequence of ON-65-ENTER. Use OFF-65-ENTER to deactivate it.

The function of OFF-65-ENTER is different when the trigger for the relay output is an alarm input. When the alarm input is activated, the relay output will also be activated immediately. When the alarm is acknowledged by OFF-65-ENTER, the first time, the relay output will NOT deactivate. It will remain on for the period selected in the menu. However, if OFF-65-ENTER is entered a second time, the relay output will deactivate immediately, no matter what time period is set in the menu. This acts as an alarm override, but the relay output will not activate again until the Alarm has been cleared and another alarm occurs.

Example: Alarm 1 is set to be NORMALLY OPEN, GO TO SHOT 1, OSD ON, and the output is set to be triggered by Input 1 for a time period of 1 min, and is connected to the Alarm Input of a digital recorder (DVR).



When the external contact is closed, the AutoDome will move to SHOT 1, flash the word *ALARM* on the display, and activate the relay output so the digital recorder starts recording. Pressing OFF-65-ENTER would clear the flashing display and change to the letter "A" in the upper right-hand corner, but the relay output will still be on and the DVR still recording. After 30 sec, the alarm input is still active, but if OFF-65-ENTER is pressed again, the relay output will turn off and the DVR will stop recording. The "A" is displayed until the alarm contact changes state.

## SECTION 8

### AutoTrack

#### WHAT IS AutoTrack?

The AutoTrack feature is a motion detector, which takes over PTZ control of the Dome. The user always has the ability to manually override by simply moving the joystick. It is sensitive to motion of all kinds, and should only be used in the same applications that a standard motion detector would be; anywhere there is little or no motion expected. It may be used in conjunction with a preset tour, or a recorded guard tour that takes periodical pauses of at least two sec during the tour. It can also be used when the dome is static (stationary in one position).

When the AutoTracker is on, it actively looks for motion. When in this state, the OSD shows the  symbol in the upper left-hand corner of the screen (see PHOTO 8A). Once motion is detected, the  begins to flash, and AutoTracker will control the PTZ of the dome. It will attempt to follow the motion, depending on the target's speed, size, and distance. Once motion is no longer detected, it will zoom out, in an attempt to re-acquire the target. If not successful, it will stop tracking. What happens next depends on the Inactivity settings of the dome. If Inactivity is set to return to Shot one, once AutoTracker gives up, the dome will return to Shot one. Similarly, if Inactivity is programmed to return to previous aux, the dome will do that as well.

The AutoTracker itself also reacts to the Inactivity setting; when the AutoTracker is on, and a user takes manual control of the camera, AutoTracker turns off. AutoTracker will remain off unless Inactivity is turned on, in which case AutoTracker will turn itself back on after the Inactivity time period expires.

Programming AutoTrack is simple. It should be completely wired to the dome before the dome is powered. If connected properly, the dome will recognize the AutoTracker, and its features will be visible throughout the AutoDome OSD menus. The only installation setting needed is in the PTZ menu under the heading *CAMERA HEIGHT*. This should be set to the approximate height of the camera from the floor of the area where targets are to be monitored. This allows AutoTracker to adjust the zoom to the optimal settings while tracking. The minimum camera height is eight ft, and the maximum is 100 ft, though performance may vary at the extremes.

The *AUTOTRACK COMMS* setting will default appropriately, based on the presence of an AutoTracker. This setting should not need to be adjusted unless there is a malfunctioning AutoTracker unit, that presents an objectionable error message on the OSD.

The User command for turning AutoTrack on and off is ON/OFF-78-ENTER.

The AutoTracker has an output relay, which can be wired to an alarm system, or to a recorder. This relay is energized whenever the AutoTracker is actively tracking an object (when  is flashing).

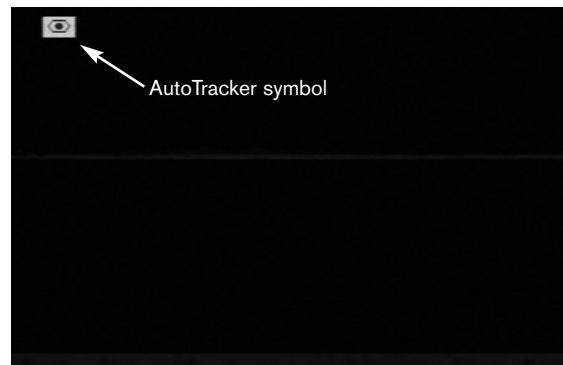

Photo 8A AutoTracker symbol

NOTE: The Pressurized housing cannot be used with the AutoTracker.

## SECTION 9

### PELCO PROTOCOL MODE

#### 9.1 Description

The Pelco Protocol Mode provides support for Pelco-P and Pelco-D protocols, and is incorporated in AutoDome firmware version 5.31 and higher. It features Auto Baud Detection which automatically detects and adjusts the AutoDome protocol and baud rate to match the controller's.

#### 9.2 Hardware Configuration

#### 9.3 RS-485 Setup

To use the Pelco Protocol Mode, the AutoDome must be configured for RS-485 operation.

1. Set the AutoDome configuration dipswitch #2 to **ON**. See *SECTION 1 and SECTION 2*.
2. Connect the RS-422 controller Tx+ terminal to the AutoDome's RxD terminal.
3. Connect the controller's Tx- terminal to the AutoDome's TxD terminal. See *SECTION 1 and SECTION 2*.

Both the Pelco controller and AutoDome must be configured before connecting the devices together. The AutoDome will respond to Bosch OSRD, Pelco-D, and Pelco-P commands.



The Pelco Mode only supports RS-485 protocol. It will not transmit responses to commands it receives.

#### 9.4 Set Addresses

- Addresses 0 to 9998 are available for Bosch OSRD commands.
- An AutoDome with an address set to 0 will respond to commands sent to any address.
- Pelco-P protocol must use addresses 1-to-32.
- Pelco-D protocol must use addresses 1-to-254.



An AutoDome that was previously configured with an address above 32 (Pelco-P upper limit) or 254 (Pelco-D upper limit) can be used without re-addressing the unit. However, care must be taken that no two addresses are repeated.

For example:

**Pelco-P** addresses above 32 are repeated in multiples of 32 (1, 33, 65, 97 are the same).

**Pelco-D** address above 254 are repeated in multiples of 254 (1, 255, 509, 763 are the same).

#### 9.5 Software

AutoDome firmware 5.31 or higher must be installed for Pelco protocol mode to operate. Procedures for uploading a new AutoDome firmware must be followed to successfully install an upgrade.



Only a Bosch VP-CFGSFT firmware upload tool (sold separately) can be used to install a firmware upgrade to the AutoDome.

#### 9.6 Commands

The Pelco **Set-Preset** command is used by AutoDome to set Presets 1 through 99. Some Presets have special meaning and override the normal preset function as follow:

##### Special Preset Commands

SET A PRESET	To set a Preset press and hold the [PRESET] button for 2 seconds.
--------------	---

92-PRESET	Sets the Left Pan limit for an AutoScan with <b>Limit Stops</b> enabled.
-----------	--

93-PRESET	Sets the Right Pan limit for an AutoScan with <b>Limit Stops</b> enabled.
-----------	---

95-PRESET	Invokes the <b>Setup Menu</b> .
-----------	---------------------------------

GO TO A PRESET	To go to a Preset momentarily press and release the [PRESET] button.
----------------	--

33-PRESET	Pans the AutoDome 180 degrees (Flip).
-----------	---------------------------------------

34-PRESET	Goes to Zero Pan.
-----------	-------------------

94-PRESET	Initiates a Preset Tour
-----------	-------------------------

96-PRESET	Stops a scan.
-----------	---------------

97-PRESET	Initiates FastAddress (Pelco Random Scan)
-----------	---

98-PRESET	Toggles the <i>Sync Mode</i> between <b>Line Lock</b> and <b>Crystal</b> (Pelco Frame Scan). This command is only accessible for 2 minutes after power is applied and then reverts to normal Preset functionality.
-----------	--

99-PRESET	Start an AutoScan. (User can enable or disable <b>Limit Stops</b> in the <b>Setup Menu</b> for AutoScan.)
-----------	---



Some Pelco controllers do not support all Preset numbers. Consult the specific Pelco controller's documentation for supported Presets.

### 9.7 Menu

To access the dome's main **Setup Menu** enter **95-[PRESET]**. AutoDome will display a list of configuration items. Some menu items can be locked and require a system password to access. The **Bosch Menu** item provides full access to the AutoDome menus.

### 9.8 Preset Titles

Preset titles can be added, removed, or changed through the main **Setup Menu** through the **Edit Presets** menu item.



Some Pelco preset titles can be 20 characters long; however AutoDome only supports 16 characters and will drop the last 4.

### 9.9 Patterns

Pelco Patterns or recordings are supported. The AutoDome supports patterns 1 and 2.

1. To start recording a Pattern, enter **#[PATTERN]** where the number specifies which of the 2 supported patterns to record.
2. The command to stop a pattern varies among different Pelco controllers. Consult the specific Pelco controller's documentation for information on setting Patterns.
3. To playback a recorded Pattern, select the desired pattern number and momentarily press (do not hold) the **[PATTERN]** key. The user can stop the playback by sending any PTZ, focus, or iris command.

### 9.10 Preset Tour

The AutoDome can be programmed to execute a Preset Tour with adjustable dwell times. To start a tour, the **Pattern 3** command must be sent from the Pelco controller by entering **3-[PATTERN]**. Consult the specific Pelco controller's documentation for information on setting Patterns.

Dwell time can be adjusted by entering **95-[PRESET]** to enter the main **Setup Menu** and then selecting the **Tour Period** menu item. Presets to include on a tour can also be added or deleted through the **Edit Tour** menu item.

### 9.11 95-PRESET Menu

When a **95-[PRESET]** command is sent from a Pelco control device, the AutoDome displays the main **Setup Menu**. Following are the menu items and a brief description:

<b>Bosch Menu...</b>	(Locked) Accesses the full AutoDome configuration menu and all AutoDome settings.
<b>Command Lock:</b>	(Locked) Allows/Disallows (ON/OFF) locked commands to be accessed.
<b>Edit Password:</b>	(Locked) Sets or displays password. See Auto Dome Security, SECTION 4 for details. (Must enter password to unlock menu even if set to 0000 or 9999.)
<b>FastAddress...</b>	(Locked) Sets/changes the dome address using the keyboard and on-screen menus.
<b>Limit Stops:</b>	(Unlocked) Enabled determines if an Auto Scan (99-PRESET) scans between left and right limits. Disabled will scan continuous 360°.
<b>Edit Tour...</b>	(Unlocked) Presets can be removed/restored (On/Off) from the Preset tour, via an on-screen menu. Presets can still be displayed manually.
<b>Edit Presets...</b>	(Unlocked) Permits modification of Preset scenes from an on-screen menu (recommended).
<b>White Balance:</b>	(Locked) Default setting when controller's white balance is off.
<b>Scan Speed:</b>	(Unlocked) On-screen menu allows the setting of the AutoPan and AutoScan speeds. Default is 30 degrees/second.
<b>Stabilization:</b>	(Unlocked) Enables/disables stabilization mode. Only available with some cameras.
<b>Tour Period:</b>	(Unlocked) On-screen menu changes the length of waiting time between presets.
<b>Recordings:</b>	(Unlocked) Used to select record Pattern 1 or 2, if normal pattern command does not respond.
<b>Night Mode:</b>	(Unlocked) Switches from color to monochrome (Day/Night models only).
<b>AutoPivot:</b>	(Locked) Allows a subject to be followed while beneath the camera, without inverting the picture. Default is ON.
<b>Software Version...</b>	(Unlocked) Briefly displays the camera software versions.
<b>Restore Factory Defaults...</b>	(Locked) Restores factory defaults.

## 9.12 Special Considerations

### Refer to the controller's user manual

To get the best results with using a specific feature, refer to the Pelco controller's user manual.

### Auto Baud Detection Feature

Baud rate and protocol are automatically detected and adjusted by AutoDome whenever the controller starts transmitting. No manual adjustments are required.

Because of the slow command repeat rate of the DX8000, Auto Baud Detection is slow. The fastest way to change the baud rate is to enter the **Setup Menu**, and select **Bosch Menu**>

**Communication Setup**> **Baud Rate** and select the desired baud rate for the AutoDome. Then change the baud rate of the controller and operate the Pan/Tilt to gain control of the AutoDome at the controller's baud rate.

If it is not possible to access the AutoDome's **Setup Menu** at the present baud rate (i.e. the baud rates of the controller source and the AutoDome are mismatched), then the **Auto Baud Detection** feature can be initiated by rapidly repeating PTZ movements or focus/iris commands for several seconds which causes the AutoDome to lock onto the controller's baud rate and protocol. This can take up to 60 seconds or more depending on the difference between the two baud rates.

### DX8000 Digital Video Recorder [SET] button

The DX8000 GUI uses the [SET] button to toggle the function of the [PRESET] button. While the [SET] button is activated (indicator is lit) the [PRESET] button is used to issue the **Set-Preset** commands. This command is used to set a preset shot or to activate the special preset functions as described in *Section 9.6: Commands*.

While the [SET] button is deactivated, the [PRESET] button is used to issue the **Go-to-Preset** command. This command is used to move the AutoDome to a previously defined preset position. This command is also used to activate special preset functions as described in *Section 9.6: Commands*.

### CM6700 Matrix Switch Presets

The AutoDome must be connected to the RS-422 Tx+/- terminal connections to **COM1** of a CM6700 matrix switch. The CM6700 configuration introduces behavior that differs from that of a direct keyboard or the DX8000 DVR configuration.

For example: When the CM6700 matrix switch sends a **Set-Preset** command to the AutoDome it will display instructions on the monitor for entering setting the title and completing the Preset. The operator must use the [F1] and [F2] keys, along with panning left and right, to set a Preset title. The operator must tilt the joy stick down to the **SET** option on the monitor until it starts blinking. Then the operator must pan right or press the [ACK] button to finish setting the Preset. Refer to the CM6700 controller user manual.

### Custom Control Software

Most custom control software that adheres to **Pelco-D** and **Pelco-P** protocol specifications will operate with the AutoDome Pelco Protocol Mode. However, custom control software that requires a response from the AutoDome will not operate because of the simplex receive requirements.

Some commands that trigger the AutoDome to solicit user input can also cause a problem for scripts run by the custom control software. For example, the **Reset Camera to Defaults** command requires the user to confirm their intent to reset the camera defaults.

## SECTION 10

### MAINTENANCE/COMPONENT REPLACEMENT

No special maintenance is required.

Occasionally, dust may accumulate inside the housing and coat the transparent dome/trim ring. In this case, power the unit off and remove the dome so that it is away from the camera. While using proper eye protection, clean the dome with clean compressed air from a spray can and microwave-safe paper towels, then reseal the dome.

In instances of high humidity, the EnviroDome may require a replacement desiccant bag. To order, contact Bosch and specify part number 303 3804 003.

#### Service Centers

U.S.A.: Phone: 800-366-2283 or 408-956-3895  
fax: 800-366-1329 or 408-956-3896  
e-mail: [NationalServiceCenter@ca.slr.com](mailto:NationalServiceCenter@ca.slr.com)  
Canada: 514-738-2434  
Europe, Middle East & Asia Pacific Region:  
32-1-440-0711

**For additional information, see**  
**[www.boschsecurity.com](http://www.boschsecurity.com).**

## SECTION 11

## TROUBLESHOOTING GUIDE

Problem	Solution
NO VIDEO	<ul style="list-style-type: none"> <li>• Ensure that the AutoDome is powered, and all cables are properly connected.</li> </ul>
NO CAMERA CONTROL	<ul style="list-style-type: none"> <li>• Ensure that the address is properly set.</li> <li>• Ensure that the biphasic or RS-232 is connected.</li> <li>• Ensure that other cameras can be controlled; if not, check the control system.</li> </ul>
CAMERA MOVES WHEN MOVING OTHER CAMERAS	<ul style="list-style-type: none"> <li>• Ensure that the address is set. If an address is set to 0000, it responds to commands for any address.</li> </ul>
PICTURE DARK	<ul style="list-style-type: none"> <li>• Ensure that GAIN CONTROL is set to AUTO (ON-43-ENTER).</li> <li>• Ensure that Iris level has not changed; if so, adjust the IRIS control on the keyboard. To permanently adjust, use ON-11-ENTER.</li> <li>• Verify proper termination.</li> </ul>
CANNOT ACCESS USER SETTINGS	<ul style="list-style-type: none"> <li>• Unlock commands (OFF-90-ENTER; may require password). <b>NOTE:</b> Commands automatically lock 30 min after being unlocked.</li> </ul>
COLORS ARE NOT CORRECT	<ol style="list-style-type: none"> <li>1. Try resetting factory defaults (ON-40-ENTER).</li> <li>2. Position camera so the entire view is white (white wall).</li> <li>3. Enter the <i>White Balance</i> menu (ON-30-ENTER). Move the joystick until one push W.G. is selected. Wait 10 sec. Press IRIS to return.</li> <li>4. If this does not work, restore factory defaults (SET-899-ENTER). Note that this erases all presets and settings.</li> </ol>
PERIODIC LOSS OF CONTROL	<ul style="list-style-type: none"> <li>• Verify that a 110 <math>\Omega</math> resistor is across the +/- biphasic code terminals at the last dome in a daisy chain configuration.</li> </ul>
BACKGROUND IS TOO BRIGHT TO SEE SUBJECT	<ul style="list-style-type: none"> <li>• Turn on backlight compensation (ON-20-ENTER).</li> </ul>
PICTURE IS ROLLING, NOISY, OR DISTORTED	<ul style="list-style-type: none"> <li>• Electronic AC power line noise may distort the picture and cause loss of Sync. If the picture is distorted, try switching to Internal Crystal (OFF-42-ENTER). If this corrects the picture problems, there may be excessive line noise on the power supply.</li> </ul>

Problem	Solution
DAY/NIGHT CAMERA DOES NOT AUTOMATICALLY SWITCH WHEN IMAGE IS DARK	<ul style="list-style-type: none"> <li>• Set GAIN CONTROL to AUTO to enable this feature.</li> </ul>
MOISTURE/DAMPNESS ON THE INSIDE OF THE BUBBLE OF THE ENVIRODOME	<ul style="list-style-type: none"> <li>• If the lower housing is equipped with a desiccant bag, it may need to be replaced (Bosch part #303 3804 003).</li> </ul>
<b>AutoTracker Errors</b>	
AN E4 OR E5 IS DISPLAYED IN THE UPPER LEFT-HAND SIDE	<ul style="list-style-type: none"> <li>• The AutoTracker is being used, and communications between the AutoDome and AutoTracker have been lost.</li> <li>• This is usually due to a wiring error. Check the RS-232 wiring to verify that RXD, TXD and GROUND are all properly connected.</li> <li>• The maximum distance between the AutoTracker and AutoDome is 50 ft.</li> <li>• The AutoTrack option communicates at the default baud rate of 19,200, but if an E5 error occurs, confirm that the baud rate in the <i>Communication Setup</i> menu is 19,200.</li> </ul>
MISSING SOME MENU SELECTIONS	<ul style="list-style-type: none"> <li>• Menu selections specific to the AutoTrack appear only if the AutoTrack option is present.</li> <li>• Some features have been added with new firmware revisions.</li> <li>• To confirm the firmware version on the monitor, use ON-66-ENTER.</li> <li>• Contact Bosch Technical Support for the most current firmware version available.</li> <li>• If the AutoDome is version 5.00 or higher, and the missing menu option requires an upgrade, purchase the Flash Upgrade kit, P/N G3-UPGRADE-5.</li> </ul>

## SECTION 12

### AUTODOME LOCKED COMMANDS

Access to the AutoDome may be password-protected. See SECTION 4, AutoDome Security for details. To use Locked Commands, first unlock the AutoDome via OFF-90-ENTER. All locked settings, except FastAddress, can then be changed via ON-46-ENTER. Disallow these commands via ON-90-ENTER.

	Commands	Keystrokes	Description
SETUP	<b>FastAddress</b>	On-999-Enter	Sets/changes the dome address using the keyboard and on-screen menus. (for cameras not already configured).
		On-998-Enter	Sets/changes the dome address using the keyboard and on-screen menus. (for all cameras, even those already configured).
	<b>Display FastAddress</b>	On-997-Enter	Briefly displays all dome addresses.
	<b>Auto Iris</b>	On/Off-3-Enter	Camera (Iris) adjusts automatically/manually (On/Off) to light conditions.
	<b>Auto Focus</b>	On/Off-4-Enter	Camera automatically/manually (On/Off) focuses.
	<b>Gain Control</b>	On/Off-43-Enter	Turns gain control to Automatic or Off. When in Automatic mode, the gain increases to compensate for darker scenes.
	<b>On-screen Display</b>	On/Off-60-Enter	Turns On/Off the On-screen Display. When off, there is no On-screen feedback.
	<b>On-screen Display Adjust</b>	On/Off-61-Enter	Changes the characters and position of the display. On-screen instructions are provided. Newer versions of the Receiver/Driver, in combination with firmware version 5.10 or higher, allow the brightness to be adjusted. The firmware automatically detects whether the Receiver/Driver supports this, and displays the selection when available.
	<b>Sector Title Edit</b>	On/Off-63-Enter	Edits the current Sector name. On-screen instructions are provided.
	<b>Sector Blanking</b>	On-86-Enter	Masks video from being displayed in selected sectors.
<b>Privacy Masking</b>	On-87-Enter	Masks video from being displayed in selected zones.	
<b>Bypass All Masks/Blanking</b>	Off-86-Enter or Off-87-Enter	Removes all viewing restrictions imposed by sector blanking/privacy masking but keeps their locations in memory. On-86/87-Enter reactivates all masks/blanking.	
GENERAL	<b>Lock/Unlock Commands</b>	On/Off-90-Enter	Allows/Disallows Locked Commands to be accessed.
	<b>Password</b>	Set-802-Enter	Sets or displays password. See AutoDome Security, SECTION 4 for details.
	<b>Factory Home Position</b>	Set-110-Enter	SET recalibrates camera and returns it to home position.
	<b>Restore Defaults</b>	On-40-Enter	Restores Factory Defaults.
PTZ	<b>Left Limit</b>	Set-101-Enter	Sets the current position as the left limit of Auto Pan. Default is 0 degrees.
	<b>Right Limit</b>	Set-102-Enter	Sets the current position as the right limit of Auto Pan. Default is 359.9 degrees.
	<b>Inactivity</b>	On/Off-9-Enter	Selects the mode that the dome reverts to after a duration without operator activity. Default is OFF.
	<b>Preset Tour Period</b>	On/Off-15-Enter	Increase/Decrease (On/Off) the time between Presets during Preset Tour.
	<b>AutoPivot</b>	On/Off-18-Enter	Allows a subject to be followed while beneath the camera, without inverting the picture. Default is ON.
	<b>AutoTrack Comms</b>	On/Off-77-Enter	Enables/Disables the Tracker. When disabled, no status will be displayed. Since this is not retained in non-volatile memory, if the AutoDome receives Tracker messages on start-up, the Tracker will be enabled again (AutoTracker option ONLY).
	<b>Camera Height</b>	On/Off-79-Enter	Selects the height of the camera in respect to the surface being monitored with the AutoTracker feature (AutoTracker option ONLY).
	CAMERA	<b>Select White Balance</b>	On/Off-35-Enter or On/Off-30-Enter
<b>Sharpness</b>		On/Off-44-Enter	Picture (vertical aperture) sharpens/softens.
<b>Iris Adjust</b>		On/Off-11-Enter	Edits the Auto Iris level.
<b>Shutter (Frame Integration)</b>		On/Off-23-Enter	Sliding scale from 1 second to 1/10,000 sec, with Auto Slow Shutter at extreme left.
<b>Sync Mode</b>		On/Off-42-Enter	Sets camera sync for external-line/internal-crystal (On/Off).
<b>Adjust Line Lock Phase</b>		On/Off-41-Enter	Changes the phase delay of the camera when in external line lock mode.
<b>Switch Polarity</b>		On-91-Enter	Switches the polarity of the Zoom, Focus, and Iris controls.
<b>Digital Zoom</b>		On/Off-80-Enter	Enables (On) or disables (Off) the digital zoom.
<b>Night Threshold Adj.</b>		On-58-Enter	Selects the video level at which the camera switches to night mode (Day/Night only).
<b>QuickSet Select</b>		On-59-Enter	Allows mode selection where multiple camera settings are set according to the chart below (Day/Night only).

QuickSet Mode Name	Gain Control	IRIS	Slow Shutter	IR Filter
Low Light Color	Auto	Auto	Auto	In
Full Auto w/ Slow Shutter	Auto	Auto	Auto	Auto
Full Auto w/o Slow Shutter	Auto	Auto	1/60	Auto
Night w/ Slow Shutter	Auto	Auto	Auto	Out
Night w/o Slow Shutter	Auto	Auto	1/60	Out

## SECTION 13

### ADVANCED MENU

#### Main Menu

Depending on the AutoDome password security set for your system, a password may be required to access the *ADVANCED MENU*. This enhanced software makes programming and customizing the AutoDome easy. All settings are editable via the Main Menu. Press ON-46-ENTER to enter the Main Menu. If no menu is displayed, the system may be locked. To unlock the AutoDome, press OFF-90-ENTER, and follow the on-screen commands to edit the settings. As indicated at the bottom of the screen, use IRIS to SAVE and EXIT or to RETURN to a previous menu.

#### CAMERA SETUP

(See FIGURE 13A for *CAMERA SETUP* menu hierarchy).

**White Balance** – This camera function maintains proper color reproduction as the color temperature of the scene changes (i.e. daylight, fluorescent). The Factory Default setting is AUTOMATIC.

**Choices:**

Extended Auto WB . . . . .Camera adjusts color using extended range.

\*Automatic WB . . . . .Camera constantly adjusts the color.

Indoor WB . . . . .Camera optimizes color for typical indoor conditions.

Outdoor WB . . . . .Camera optimizes color for typical outdoor conditions.

One Push WB . . . . .Sets the camera's color settings for the current scene. Zoom on a well lit, white object (i.e. a white wall or paper) before activating.

---

**Gain Control** – Electronically brightens darker scenes which may cause graininess in low light scenes. The Factory Default setting is AUTO.

**Choices:**

Off . . . . .Camera uses only the IRIS to adjust to low light.

\*Auto . . . . .Camera adds electronic gain based on lighting conditions.

---

**Max Gain Level** – Adjusts the maximum gain level that Gain control will adjust to when set to AUTO.

**Choices:** . . . . .Sliding Scale from 1 to 6 (in 4 dB gain steps).

---

**Sharpness** – Adjusts the sharpness/detail of the picture. The Factory Default setting is six on the sliding scale of about 16.

**Choices:** . . . . .Sliding Scale from –(soft) to +(sharp).

---

**Synch Mode** – Sets the synch mode of the camera. The Factory Default setting is LINE LOCK.

**Choices:**

Crystal . . . . .Camera is synchronized to an internal crystal (recommended if there is noise on the power line).

\*Line Lock . . . . .Camera is synchronized to AC power. This eliminates picture roll in multicamera systems.

---

**Line Lock Delay** – Optimizes LINE LOCK mode to eliminate picture roll in multiphase power applications. The Factory Default setting is zero.

**Choices:** . . . . .Sliding Scale (–0° to 359°).

---

**Backlight Compensation** – Improves the image quality when the background has a high level of illumination.

**Choices:** . . . . .On, Off.

---

**Shutter** – Sliding scale from 1 sec to 1/10,000 sec, with Auto Slow Shutter at extreme left.

---

**Restore Defaults** – Restores ALL choices, for this submenu ONLY, back to the Factory Defaults.

**Choices:** . . . . .Yes, No.

---

**NOTE:** The following four (4) CAMERA SETUP options pertain to Day/Night models only, and will not appear on the screen otherwise.

**Night Mode** – Selects night mode (B/W) operation (Day/Night models only).

**Choices:** .....On, Off, Auto.

---

**Night Mode Threshold** – Adjusts the level of light at which the camera automatically switches to night mode (B/W) operation (Day/Night models only).

**Choices:** .....Sliding Scale from 10 to 55 (in increments of five).

---

**Night Mode Color** – Determines if color processing remains in effect while in night mode (Day/Night models only).

**Choices:**

On .....Color burst remains in video signal. Picture has a greenish shade of B/W.

\*Off .....Video is true B/W without color burst in video signal.

---

**QuickSet Mode** – Selects one of several modes where camera settings are set according to the preceding AUTODOME LOCKED COMMANDS chart in SECTION 12 (Day/Night models only).

---

### LENS SETUP

(See FIGURE 13B for *LENS SETUP* menu hierarchy).

**Auto Focus** – AutoDome automatically focuses on the subject in the center of the screen. The Factory Default setting is SPOT.

**Choices:**

Constant .....Auto Focus is always active, even while moving.

Manual .....Auto Focus is inactive; manual focus must be used.

\*Spot .....Auto Focus activates after the camera stops movement. Once focused, Auto Focus is inactive until the camera is moved again.

---

**Auto Iris** – AutoDome automatically adjusts to varying light conditions. The Factory Default setting is CONSTANT.

**Choices:**

\*Constant .....Auto Iris is constantly active.

Manual .....Iris must be manually adjusted.

---

**Auto Iris Level** – Reduces the camera's Iris reference level for proper exposure.

**Choices:** .....Sliding scale from – (reduce brightness) to + (increase brightness).

---

**Focus Speed** – Adjusts the manual focus speed. The Factory Default setting is two.

**Choices:** .....Sliding Scale from 1 (normal) to 8 (fast).

---

**Iris Speed** – Adjusts the manual iris speed. The Factory Default setting is five.

**Choices:** .....Sliding Scale from 1 (normal) to 10 (fast).

---

**Max Zoom Speed** – Adjusts the manual zoom speed. The Factory Default setting is FAST.

**Choices:** .....Fast\*, Medium, and Slow.

---

**Digital Zoom** – Enables digital zoom. The Factory Default setting is ON.

**Choices:**

\*On .....When the camera reaches maximum optical zoom, the image is electronically zoomed (up to 12X).

Off .....When the camera reaches maximum optical zoom, it does not electronically zoom.

---

**Restore Defaults** – Restores ALL of the choices, for this submenu ONLY, back to the Factory Defaults.

**Choices:** .....Yes, No.

---

**PTZ SETUP**

(See FIGURE 13C for the PTZ SETUP menu hierarchy).

**Autopan Speed** – Adjusts speed of the camera during Auto Pan/ Auto Scan. The Factory Default setting is 30°/sec.

**Choices:** .....Sliding Scale from 1°/sec to 60°/sec.

---

**Tour Period** – Changes dwell time between Presets during a Preset Tour. The Factory Default setting is five sec.

**Choices:** .....Sliding Scale from 3 sec to 10 min.

---

**PTZ Fixed Speed** – Sets Pan/Tilt speed when controlled by a fixed speed controller. The Factory Default setting is four.

**Choices:** .....Sliding Scale from 1 (slow) to 15 (fast).

---

**Inactivity** – Selects the mode that the dome reverts to after the period of time specified in the **Inactivity Period** (next menu option), without operator activity. The Factory Default setting is OFF.

**Choices:**

\*Off .....Remains on current scene indefinitely.

Scene 1 .....Returns to Preset 1.

Prev Aux .....Returns to previous activity (previous activities include Aux commands 1, 2, 8, 50, 52).

---

**Inactivity Period** – The time period of inactivity before the above action occurs. Default setting is two min.

**Choices:** .....Sliding Scale from 3 sec to 10 min.

---

**AutoPivot** – AutoPivot automatically rotates the camera 180° when following a subject travelling directly beneath the camera. The Factory Default setting is ON.

**Choices:**

\*On .....Camera automatically pivots.

Off .....Camera stops tilting when looking straight down.

---

**Restore Defaults** – Use this to restore ALL choices for this submenu ONLY, back to the Factory Defaults.

**Choices:** .....Yes, No.

---

NOTE: The following two (2) PTZ SETUP options refer to AutoTrack models only, and will not appear on the screen otherwise.

---

**AutoTrack Comms:** – Enables/Disables the AutoTracker completely, including all communications.

**Choices:** .....On (enable), Off (disable).

---

**Camera Height:** – Selects the height of the camera in relation to the surface being viewed.

**Choices:** .....From 2.4 m to 30.7 m (8 ft to 100 ft); use the Joystick Up/Down to adjust.

---

**DISPLAY SETUP**

(See FIGURE 13D for DISPLAY SETUP menu hierarchy.)

**Title OSD** – Controls whether sector or shot title are displayed. The Factory Default setting is MOMENTARY.

**Choices:**

\*Momentary .....Titles are displayed for a few sec, then disappear from the screen.

On .....Titles are displayed.

Off .....Titles are hidden.

---

**Camera OSD** – Controls whether the camera information is displayed (such as digital zoom, Iris OPEN/close, etc.).

The Factory Default is ON.

**Choices:**

\*On .....Camera commands are displayed.

Off .....Camera commands are hidden.

---

**Display Adjust** – Adjusts the vertical position of the on-screen display. See the on-screen display for instructions.

---

**Sector Blanking** – Selects sectors for video blanking. Sectors available are 1 to 16. See the on-screen display for instructions.

---

**Privacy Masking** – Up to six (6) privacy masks are available to mask out sensitive areas.

---

**Restore Defaults** – Restores ALL choices for this submenu ONLY, back to the Factory Defaults.

**Choices:** .....Yes, No.

---

**COMMUNICATION SETUP**

(See FIGURE 13E for COMMUNICATION SETUP hierarchy).

**Baud Rate** – Controls baud rate for AutoDome communication in the Normal mode. Factory Default is 9600.

**Choices:** .....9600\*, 19200, 38400, 57600.

---

**Bilinx** - Enables/Disables the Bilinx communications directly through the coax. Factory Default is ON.

**Choices:** .....On\*, Off.

---

**Restore Defaults** – Restores ALL choices for this submenu ONLY, back to the Factory Defaults.

**Choices:** .....Yes, No.

---

**ALARM SETUP**

(See FIGURE 13F for ALARM SETUP hierarchy).

**Input 1 thru 4** – Contains a submenu of choices for Input type, and the action to occur when the alarm is activated.

**Alarm 1 through 4**

**Input** – Controls the input type that the camera will be expecting. Factory Default is OFF.

**Choices:** .....OFF\*, Normally Open (N.O.), Normally Closed (N.C.).

---

**Action** – There are three standard choices to determine how the AutoDome will respond when an alarm input is activated, and one additional choice that will appear ONLY when the AutoTracker is being used.

---

**Go to Shot** – The AutoDome moves to the pre-position (shot) selected. Default is the input number.

**Choices:** .....0 to 99.

**NOTE:** If 0 is selected and OSD is set to YES, the camera will not move, but will display a flashing *ALARM* prompt.

---

**OSD** – Controls whether a visual *ALARM* prompt will be displayed. Default is YES.

**Choices:** .....Yes\*, No.

---

**Transmit** – Controls whether an alarm message will be transmitted via RS-232/RS-485. Default is NO.

**Choices:** .....Yes, No\*.

---

**Track** – Controls whether AutoTrack should be activated when an alarm occurs. Displayed on AutoTrack models ONLY.

**Choices:** .....Yes, No.

---

**AutoTrack / Relay Output** – Contains a submenu of choices that control how the relay output will function.

**Period** – Controls the time period that the relay output will remain activated. Default is FOLLOW INPUT.

**Choices:**

FOLLOW INPUT\* – The relay output will remain activated as long as the alarm input is active.

LATCHED – The relay output will latch ON and remain activated until an OFF-65 command is sent twice. The first OFF-65 command clears the alarm OSD from the display; the second OFF-65 command deactivates the output.

SLIDING SCALE – from 1 sec to 10 min. The relay output remains activated for the selected time period.

**Trigger By:** Select which alarm input will cause the relay output to Activate. Trigger By applies to Relay Output only, not AutoTrack.

**Choices:** .....Input 1 through 4: Yes, No.

**Alarm Status** – Displays the states of the Alarm inputs and the relay output. This is an active display, that changes as the Alarm Status changes. It is informational only.

---

**Restore Defaults** – Restores ALL choices for this submenu ONLY, back to the Factory Defaults.

**Choices:** .....Yes, No.

---

**LANGUAGE SETUP**

(See FIGURE 13G for LANGUAGE SETUP hierarchy.)

**Language** – Selects the language to be displayed.

**Choices:** English, Spanish, French, German, Polish and Portuguese.

---

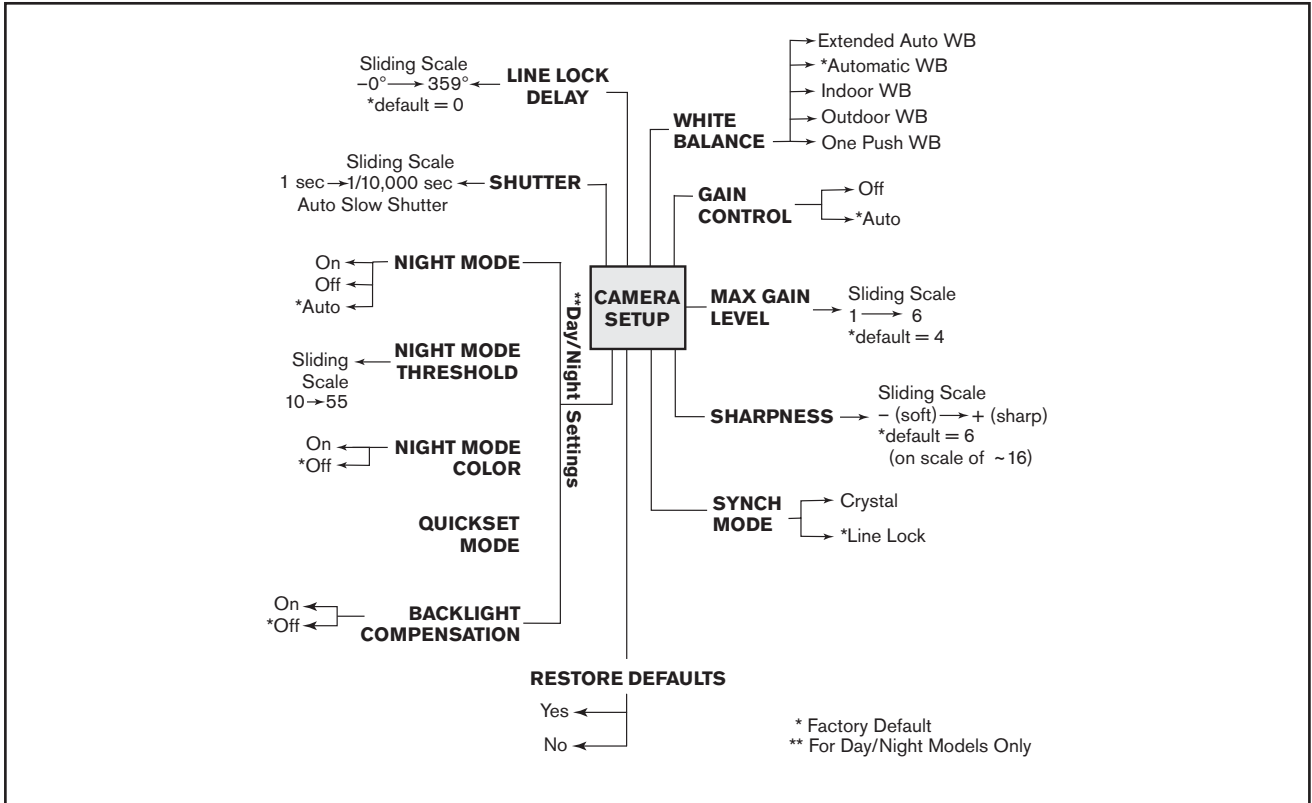

Figure 13A Camera Setup

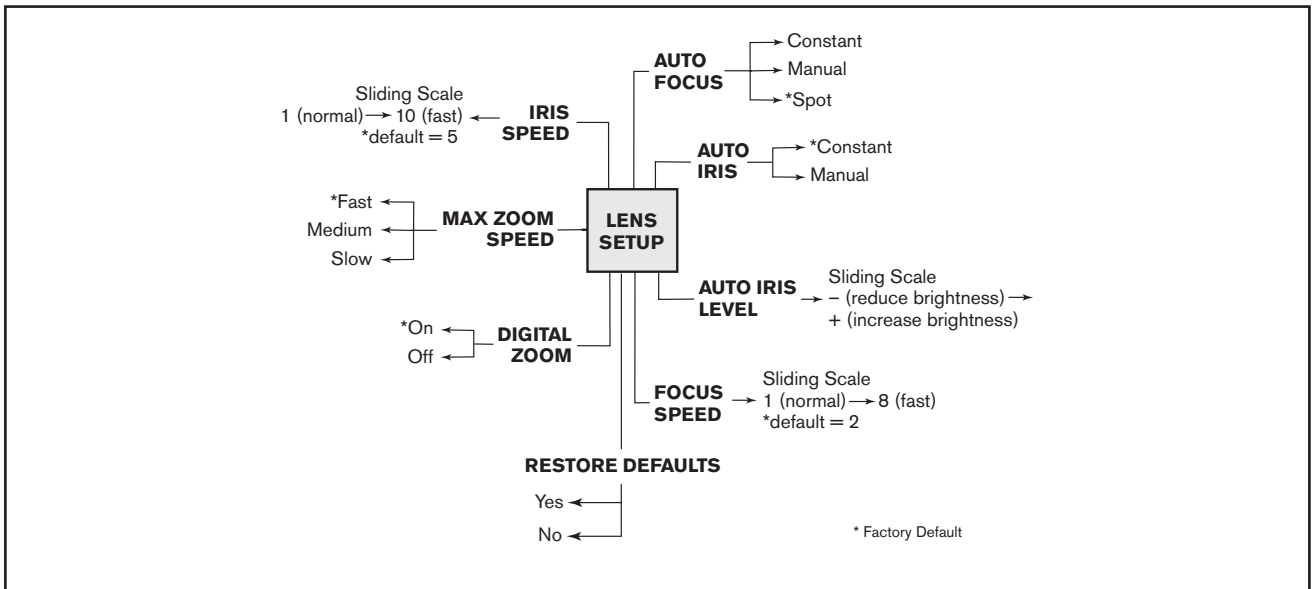

Figure 13B Lens Setup

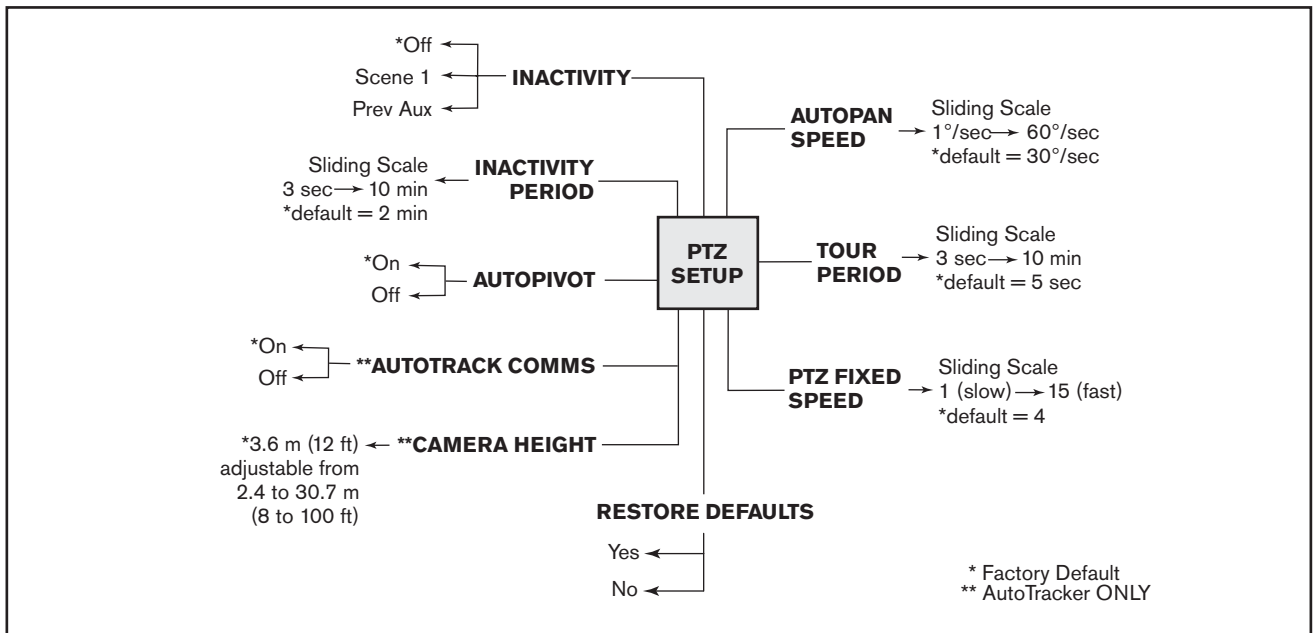

Figure 13C PTZ Setup

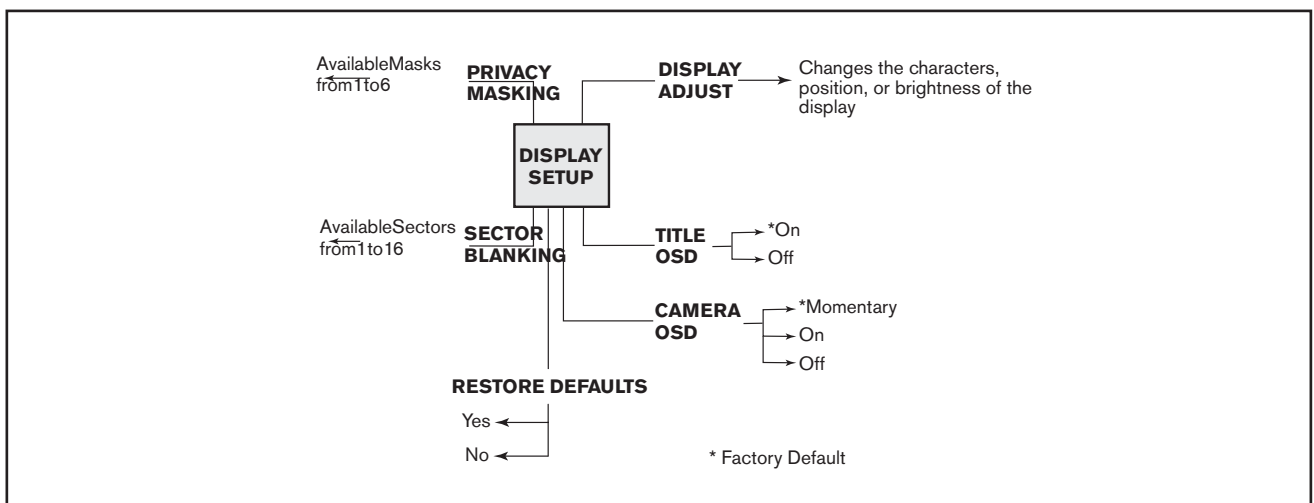

Figure 13D Display Setup

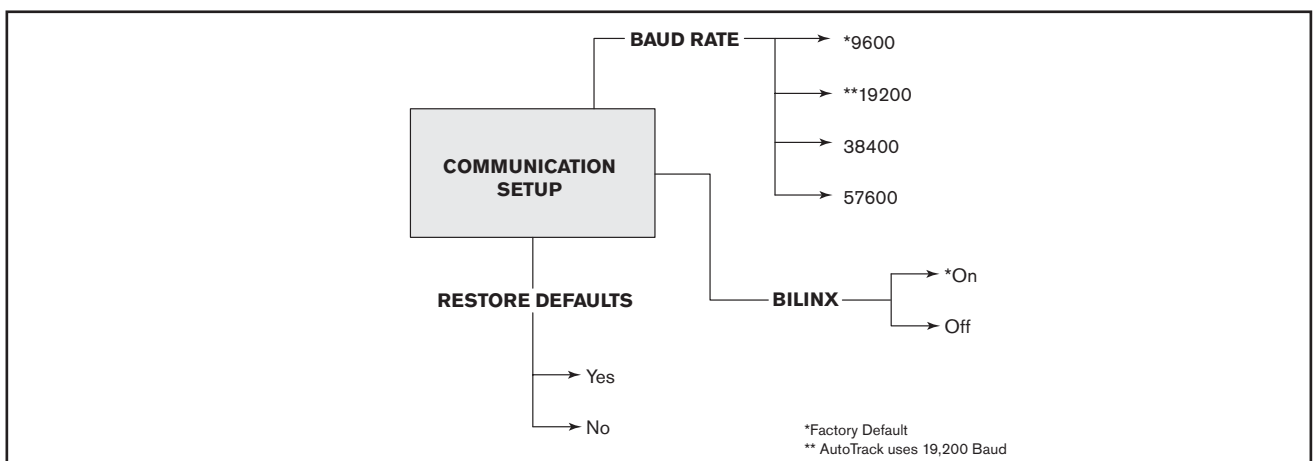

Figure 13E Communication Setup

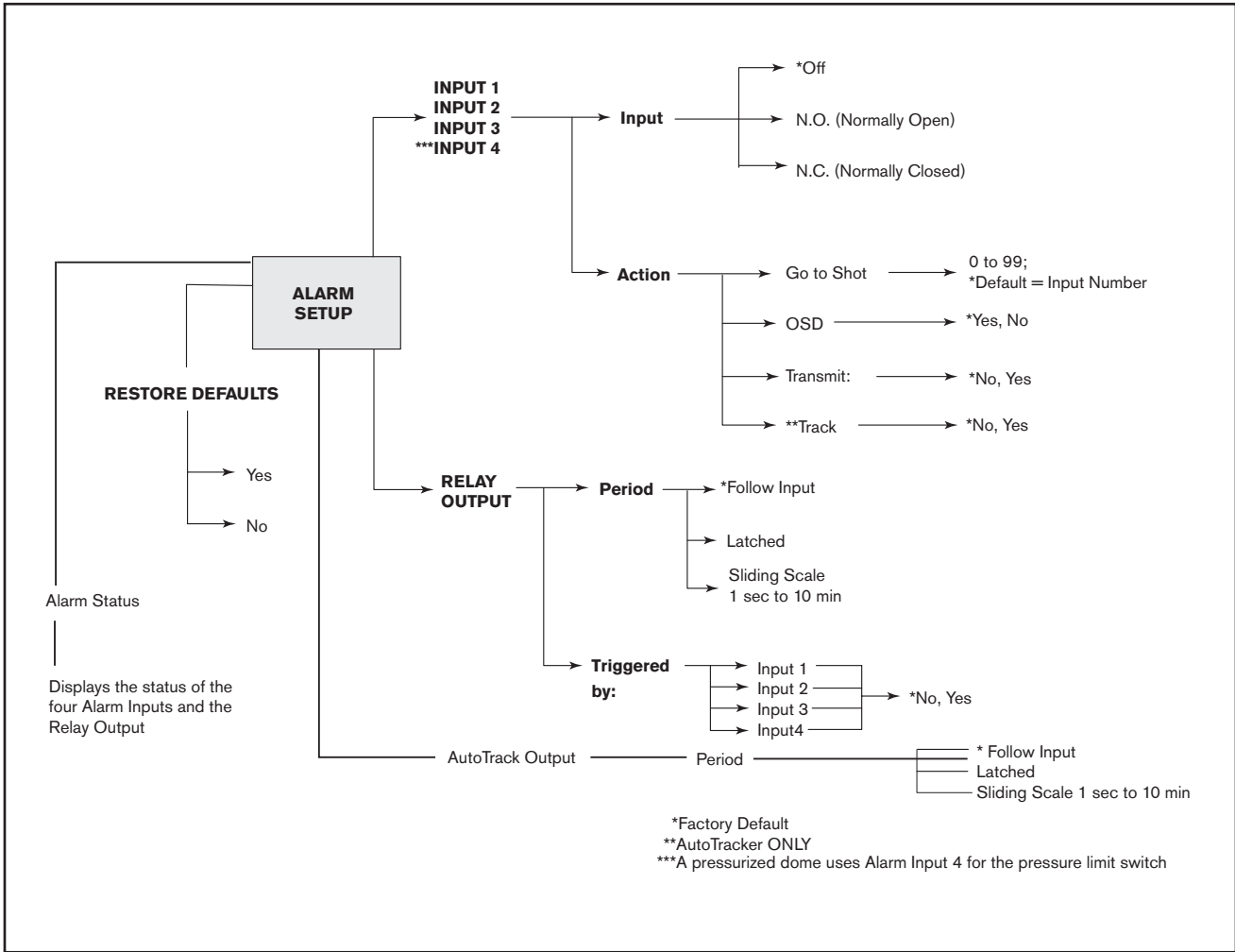

Figure 13F Alarm Setup

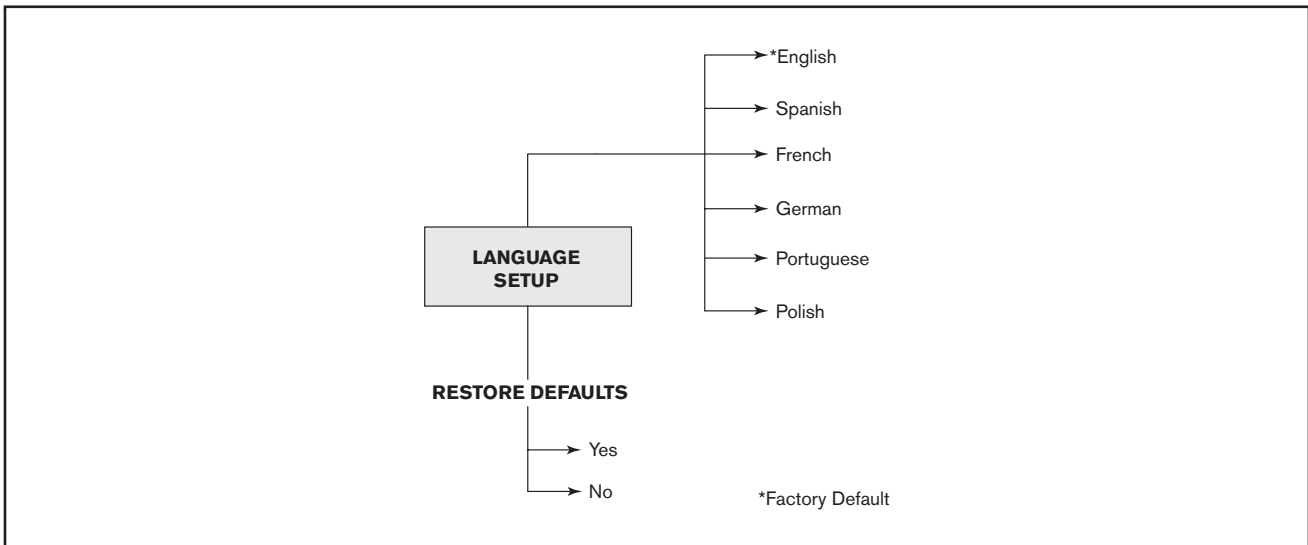

Figure 13G Language Setup

# APPENDIX A

## Power Wiring Guide

### AutoDome Power Wiring Connections

Refer to the following diagram to ensure proper wiring of the AutoDome. If using the ENV-PSU for power, use the THREE WIRE POWER distances identified below.

**WARNING:** Failure to correctly wire the power to the EnviroDome could result in heater malfunction.

**NOTE:** If using the ENV-PSU with the AutoTracker option, the RS-232 connections (RXD, TXD, GND) must be used.

The maximum distance for RS-232 communications is 50 ft.

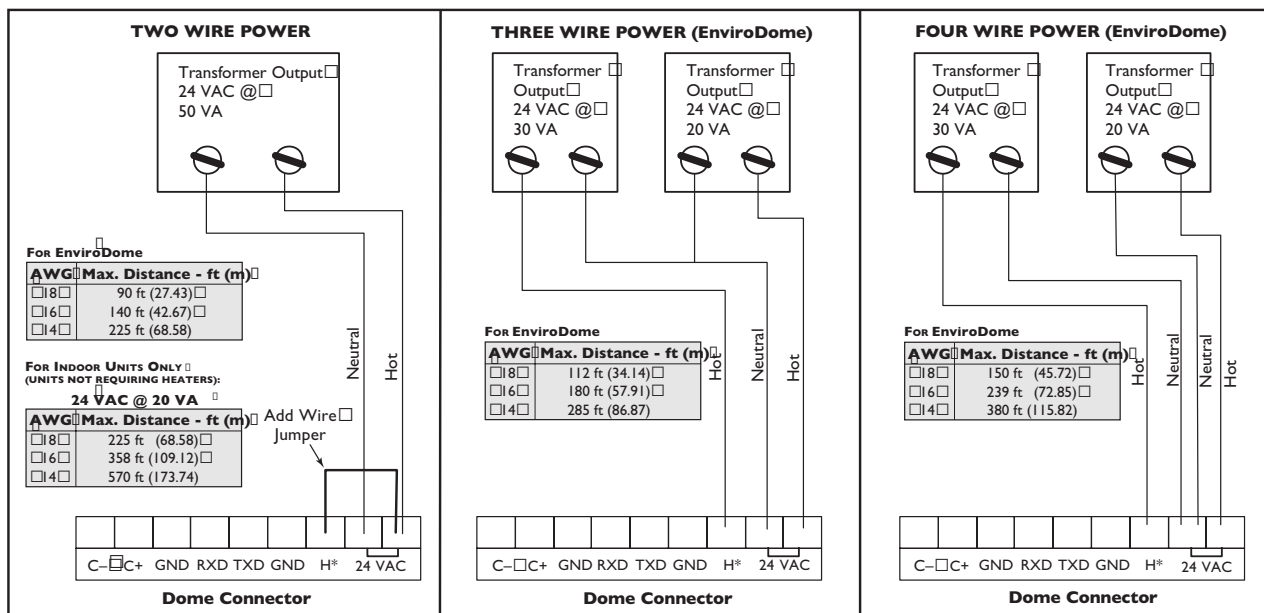

\*Heater connection for EnviroDome only.

**APPENDIX B**

**Gasket Installation (to meet IP66/NEMA 4X, Dust-tight and Powerful Jetting)**

Install Gasket with Lip on Top.

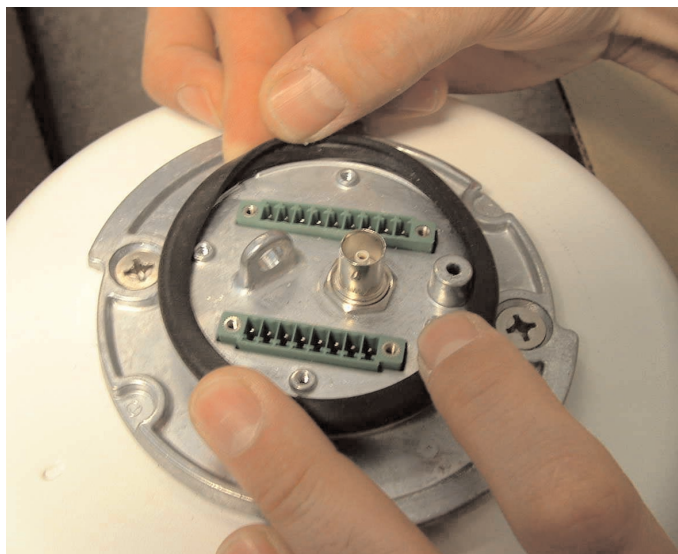
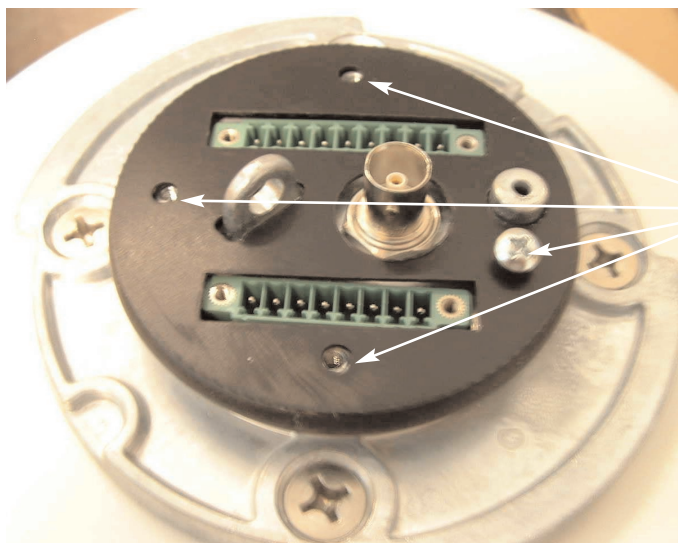

Plate Holds Gasket Securely



Insert 4 Screws

# AutoDome<sup>®</sup> and EnviroDome<sup>®</sup> Indoor Pendant In-ceiling Model User Manual Version 5.3



Security Systems

EN

**AutoDome**  
with AutoTrack



**NOTE:** Remove this User Manual and supply to user.

Security you can rely on

# BOSCH

## ON-SCREEN PROGRAMMING

The AutoDome software offers user-friendly, on-screen programming. A few common commands are shown below. Additional commands are listed at the end of this manual.

### Saving a scene (Preset)

The AutoDome allows up to 99 scenes to be saved and recalled instantly. A saved scene is called a Preset. When a Preset is saved, the position, zoom, and most camera settings are stored.

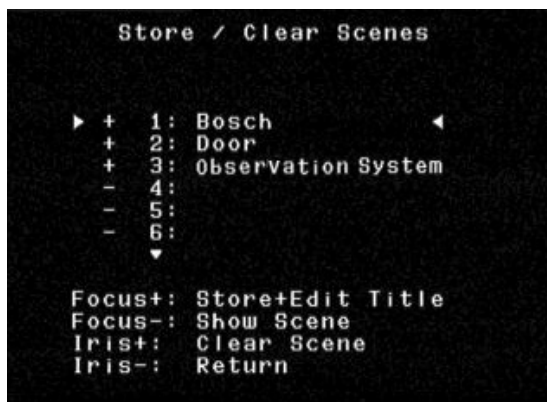

Figure 1 Preset menu

SET-100-ENTER displays the *Preset* menu (see FIGURE 1). Menu options are store, delete, name, or edit. Up to 99 scenes can be saved, and the system automatically selects the next available number. When a Preset is saved, it can be named via the joystick, FOCUS, and IRIS (see FIGURE 2). The name can be up to 16 characters long. This Preset can later be viewed using the SHOT #-ENTER command, where # is 1-99.



Figure 2 Naming a scene (Preset)

### Preset Tour

Once Presets are stored, the AutoDome can cycle through all Presets or selected Presets. This is called a Preset tour. To include or remove presets on a tour, type SET-900-ENTER. This displays the current Presets, and indicates if they are on the tour. Follow the on-screen instructions to include/remove Presets from the tour.

**Note:** Presets removed from the tour can still be accessed manually).

Type ON-8-ENTER to activate the preset tour. To change the time duration between presets, type ON-15-ENTER and follow the on-screen instructions.

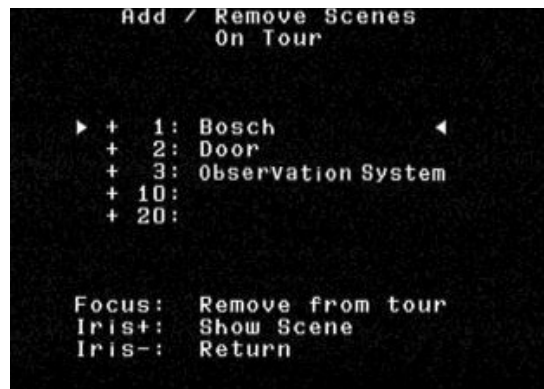

Figure 3 Preset tour menu

### Setting the Preset Tour period

To change the time duration between presets in a Preset Tour, type ON-15-ENTER, and use the joystick for adjustments (see FIGURE 4).



Figure 4 Preset tour period adjustments

### Record/Playback Tours

Two independent macros (series of commands) can be recorded; A & B. These macros can be several hours in duration, although tours involving constant commands only last minutes. While recording, the on-screen display indicates remaining memory (see FIGURE 5). To begin recording on A, move the camera to the desired starting point and type ON-100-ENTER. The AutoDome now records all camera activities, until the recording is ended by OFF-100-ENTER. Once A has been recorded, B is available via the ON/OFF-101-ENTER command. Playback can be continuous (ON-50-ENTER for A; ON-52-ENTER for B) or one shot (ON-51-ENTER for A; ON-53-ENTER for B).



Figure 5 Recording

### Changing AutoPan and AutoScan speeds

The AutoPan and AutoScan speeds (see FIGURE 6) can be adjusted via ON-14-ENTER. Use the joystick to adjust the speed. It is helpful for the Pan or Scan to be active when entering ADJUST mode, to see the speed change.

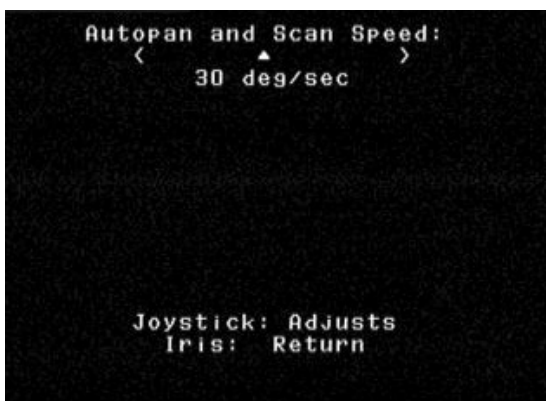

Figure 6 AutoPan / AutoScan speed adjust

## AUTODOME USER COMMANDS

## UNLOCKED COMMANDS

	Commands	Keystrokes	Description
PTZ	<b>Scan</b>	ON/OFF-1-ENTER	Camera continuously pans in the last direction that the joystick was moved. Moving the joystick stops the scan.
	<b>AutoPan</b>	ON/OFF-2-ENTER	Camera continuously pans back and forth between limits. Moving the joystick stops the scan.
PRESET	<b>Preset Menu</b>	SET-100-ENTER	Permits modification of Preset scenes from an on-screen menu (recommended).
	<b>Preset Tour</b>	ON/OFF-8-ENTER	Camera cycles through Preset Scenes. Moving the joystick stops the tour.
	<b>Preset Tour Period</b>	ON/OFF-15-ENTER	On-screen menu changes the length of waiting time between presets.
	<b>Preset Save</b>	SET-1-99-ENTER	Stores the current scene and camera settings in memory. Preset 1 is shown when the camera is initialized.
	<b>Preset Call</b>	SHOT-1-99-ENTER	Recalls the scene and camera settings from memory.
	<b>Edit Preset Title</b>	ON/OFF-62-ENTER	Modifies the Preset names. On-screen instructions are provided.
	<b>Edit Preset Tour</b>	SET/SHOT-900-ENTER	Presets can be removed/restored (On/Off) from the Preset tour, via an on-screen menu. Presets can still be displayed manually.
ALARM	<b>Modify Preset Tour</b>	SET/SHOT-901-999-ENTER	Presets can individually be removed/restored (On/Off) from the Preset tour. Example: SET-915-ENTER will clear Preset 15 from the tour. Presets can still be displayed manually.
	<b>Alarm Clear/Relay Output</b>	ON/OFF-65-ENTER	If an alarm has been activated and the <i>ALARM</i> message is being displayed, it may be cleared by using OFF-65-ENTER once. When OFF-65 ENTER is pressed again, the relay output will be deactivated. ON-65-ENTER will activate the relay output regardless of alarm conditions.
RECORD	<b>Record A</b>	ON/OFF-100-ENTER	Records "A" camera and PTZ controls, that can be played back. Once the sequence is recorded, you must exit record to play back.
	<b>Record B</b>	ON/OFF-101-ENTER	Records "B" camera and PTZ controls, that can be played back. Once the sequence is recorded you must exit record to play back.
	<b>Continuous Playback A</b>	ON/OFF-50-ENTER	Camera will repeat "A" recorded sequence.
	<b>Playback A</b>	ON/OFF-51-ENTER	Camera will play the "A" recorded sequence once.
	<b>Continuous Playback B</b>	ON/OFF-52-ENTER	Camera will repeat "B" recorded sequence.
	<b>Playback B</b>	ON/OFF-53-ENTER	Camera will play the "B" recorded sequence once.
	SETUP	<b>Scan+Auto Pan Speed</b>	ON/OFF-14-ENTER
<b>Backlight Compensation</b>		ON/OFF-20-ENTER	Camera will adjust for a bright background.
<b>View Factory Settings</b>		ON-47-ENTER	Displays the factory default settings.
<b>Software Version</b>		ON-66-ENTER	Briefly displays the camera software versions.
<b>Night Mode</b>		ON/OFF-57-ENTER	Switches from color to monochrome (Day/Night models only).
<b>Day/Night Menu</b>		ON-56-ENTER	On-screen menu changes Night Mode setting (On/Off/Auto; Day/Night only).
	<b>AutoTrack</b>	ON/OFF-78-ENTER	Allows the operator to turn tracking On and Off (AutoTrack Option only).

Distribuidor Autorizado:  
 Segurança Industrial Equipamentos  
 Fone/Fax: (41) 4063-9687 ou 3287-1364  
 www.segind.com.br - cml@segind.com.br

© 2005 Bosch Security Systems GmbH

3935 890 43816 05-07 | Updated February 15, 2005 | Data subject to change without notice.

**Di stribui dor Autori zado:**  
**Segurança Industrial Equipamentos**  
**Fone/Fax: (41) 4063-9687 ou 3287-1364**  
**www.segi nd. com. br - cml@segi nd. com. br**

**BOSCH**